

EZ-Fold Platform 2-Ebike Rack

10104118

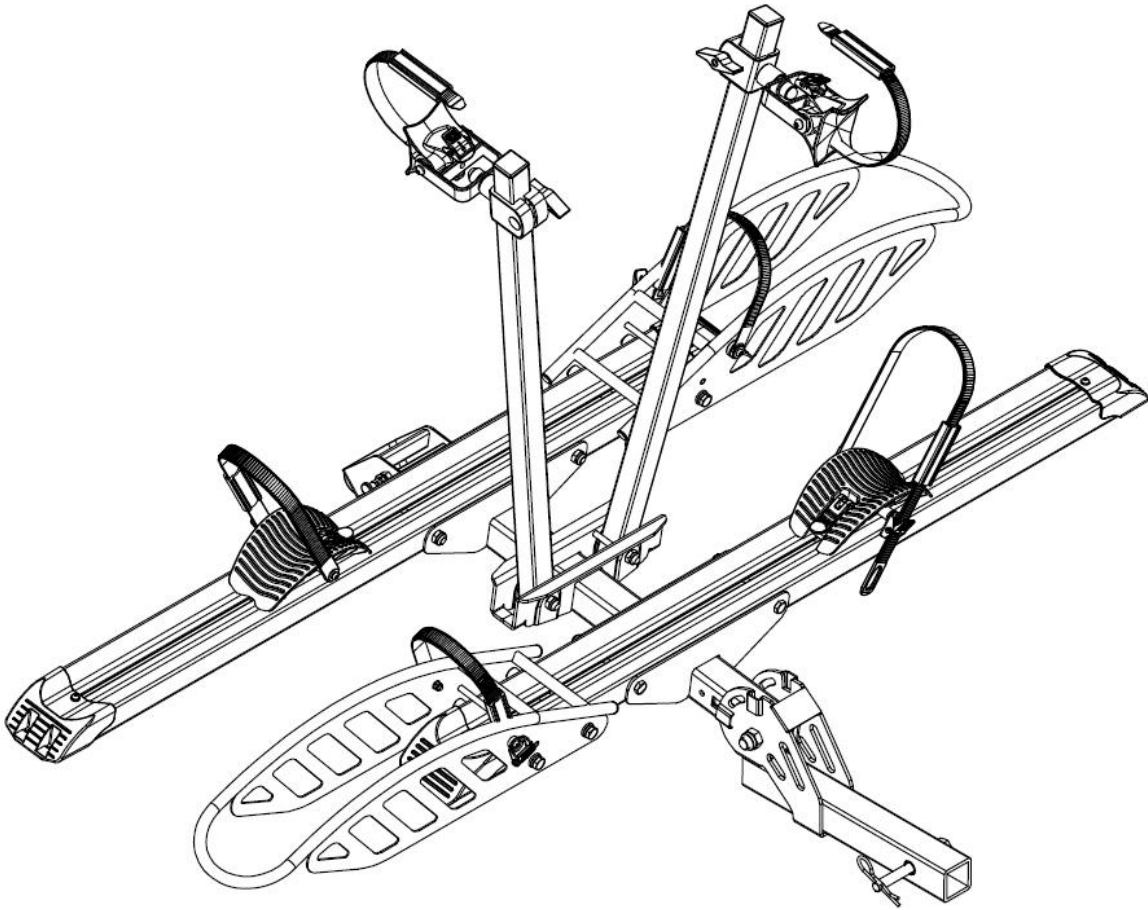

Technical Specifications

Property	Specification
Length	69.1"
Width	43.5"
Height	40.6" (MAX)
Maximum Weight Capacity	200LBS

Diagram

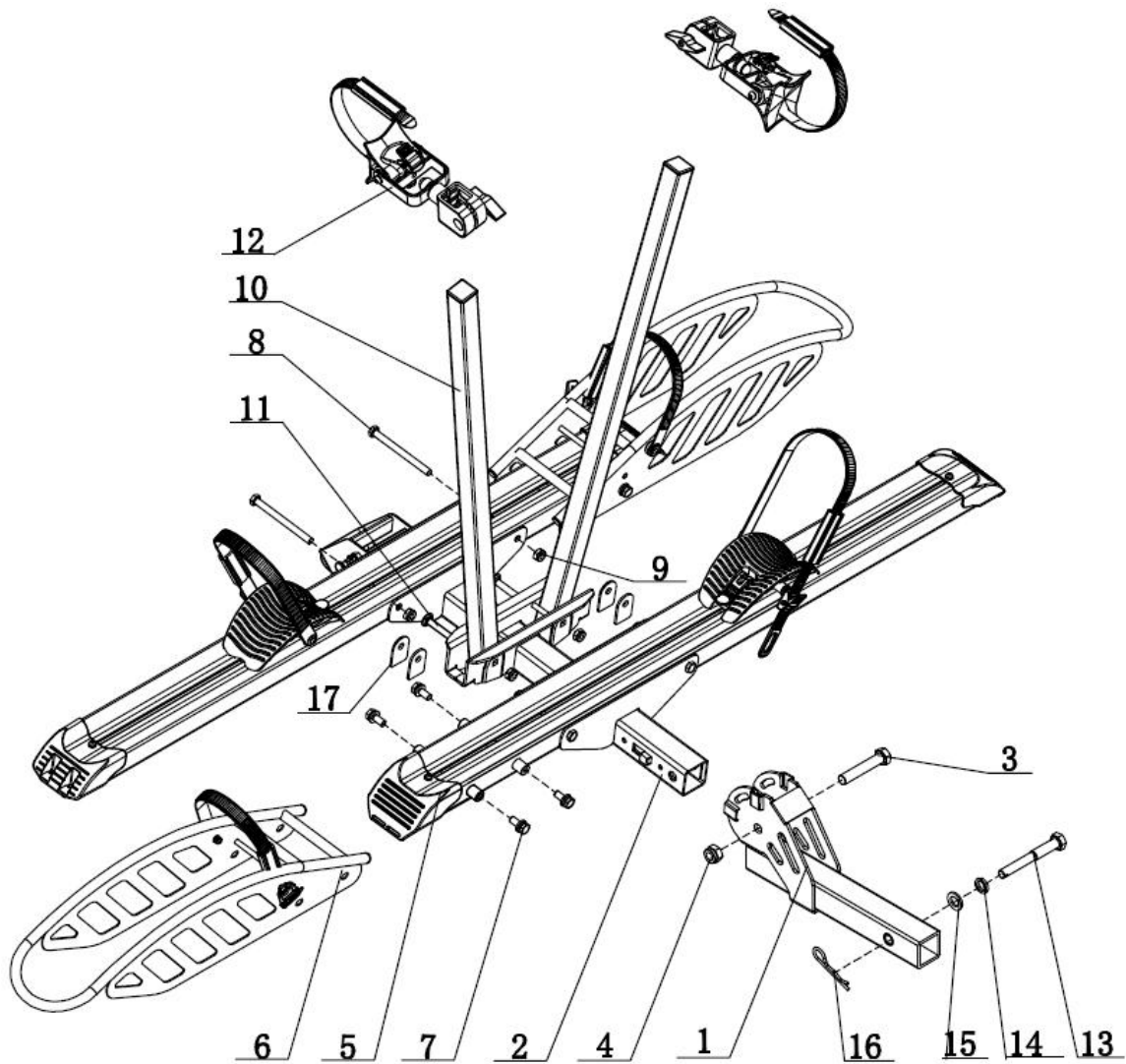

Parts List

Part #	Description	Qty	Part #	Description	Qty
1	Rotating Group	1	10	Middle Support Tube	2
2	Bottom fixing bracket	1	11	M10x65 Bolt	2
3	M16x85 Hexagon Bolt	1	12	Connecting block	2
4	M16 Lock Nut	1	13	M16 Shockproof Bolt	1
5	Crossbeam	2	14	φ16 Spring Washer	1
6	Front Wheel Holder	2	15	φ16 Flat Washer	1
7	M10x25 Hexagonal Triple Combination Bolt	8	16	φ3.8 Pin	1
8	M10*120 Hex Bolt	4	17	Half Round Gasket	4
9	M10 Lock Nut	6			

WARNING

- Do not overload beyond bike rack's weight capacity of 200lbs.
- Do not carry more than 2 bikes on the carrier.
- The bike rack is not intended for transporting humans or animals.
- If you are planning to load only one bike, it is recommended to place it in the position closest to the vehicle.
- All bikes must be secured properly before operating the vehicle.
- Make sure the front of the bike(s), when mounted, are at or above the bottom of the bumper to avoid damage to the bike(s).
- Do not carry flammable items on the bike rack.
- If using the bike rack to transport electric bicycles, please remove the batteries from the bicycles prior to transporting. This will help reduce the weight supported by the carrier.
- During long trips, frequently check the straps and bike position, especially if traveling on rough terrain.
- Please do not make alterations to the product, as it can pose potential hazards to your safety.
- Failure to heed these warnings may result in personal injury and/or property damage.
- To prevent serious injury or death, inspect the bike rack for any signs of wear, corrosion and fatigue before each use. Do not use the bicycle rack if parts are bent, broken, deformed or missing. If parts are bent, broken, damaged or missing, remove the rack from your vehicle before operating the vehicle.

Recommended Tools for Assembly (Not Included)

Monkey Wrench (1pc): Size=300mm

Open Wrench (1pc): Size=17mm

Open Wrench (1pc): Size=24mm

Assembly Instructions

Step 1: Align the bottom fixing bracket assembly (2) with the hole of the rotating mechanism assembly (1), insert the M16*85 outer hexagon bolt (3), and then screw on the M16 lock nut (4). Note: Do not overtighten the bolts, as this will prevent (2) and (1) components from rotating easily.

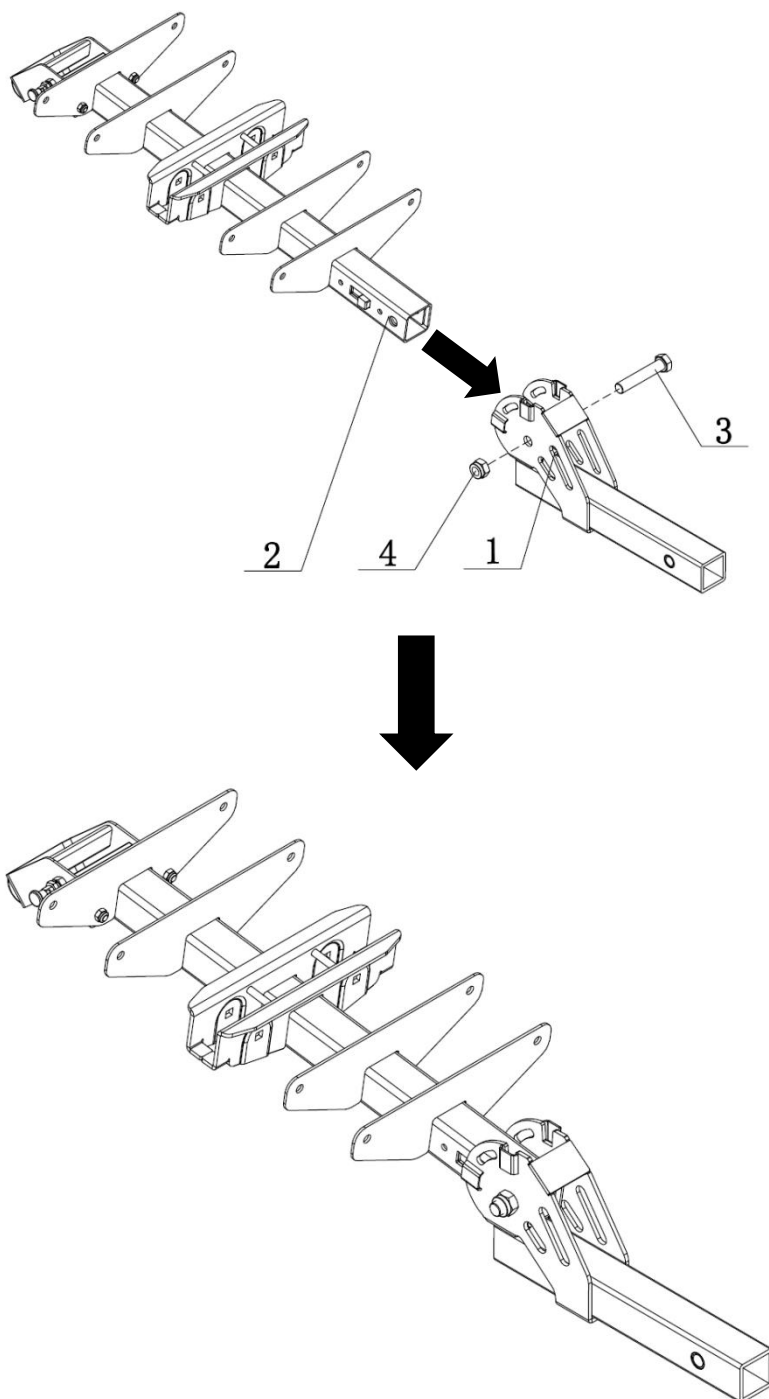

STEP2: Align the holes from Front Wheel Holder (6) and Crossbeam (5). Then fix them with M10x25 Hexagonal Triple Combination Bolt (7).

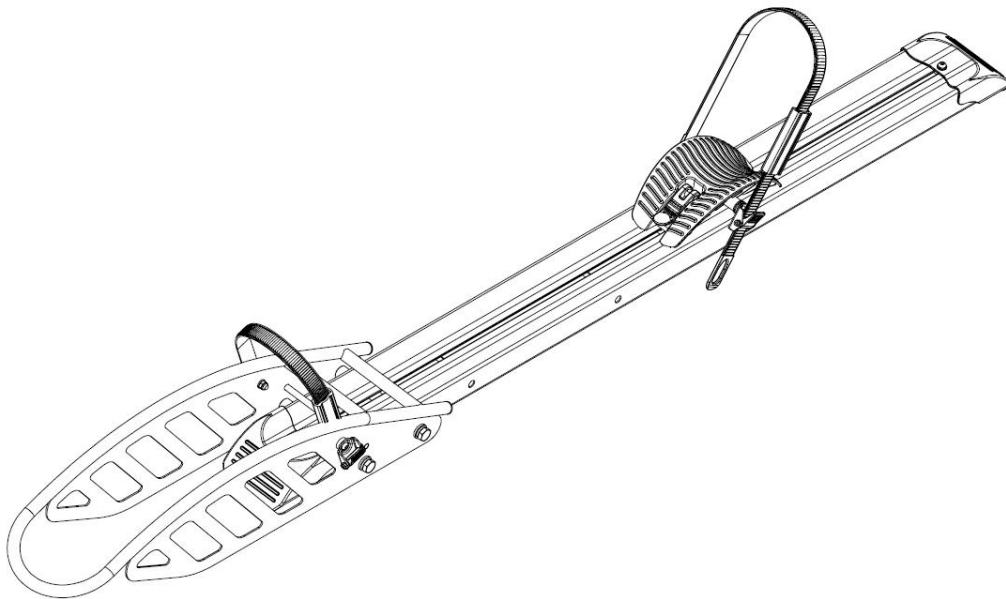
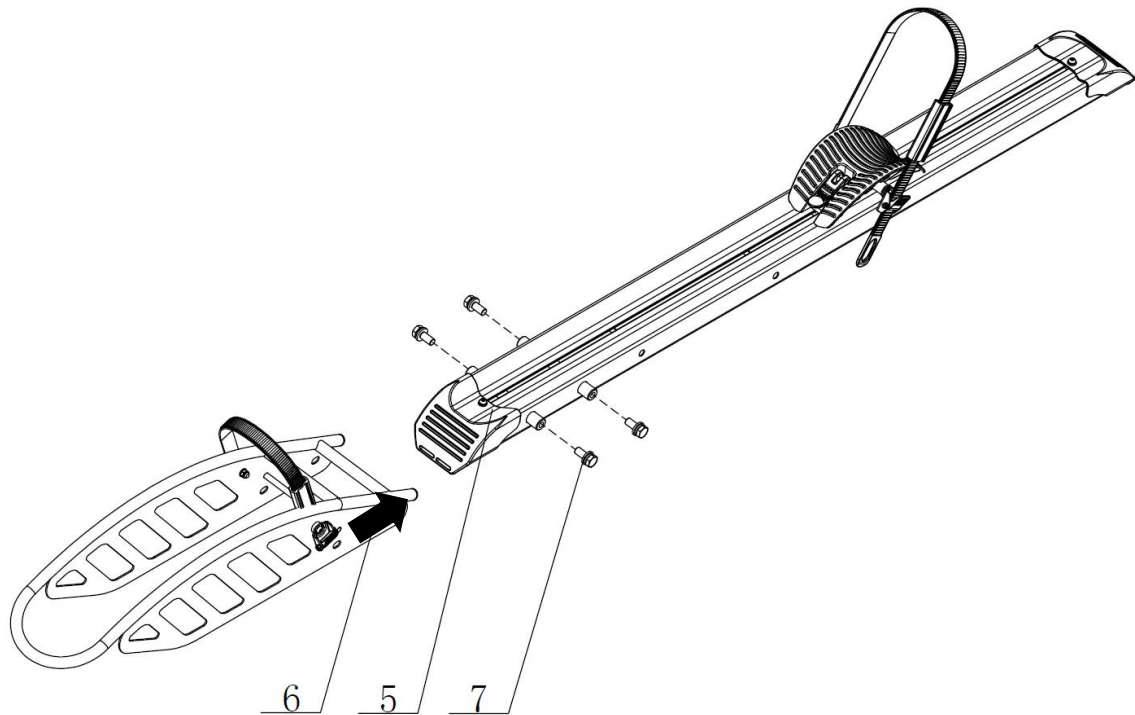

Step 3: Place the components assembled in steps 2 above into the bottom fixing bracket assembly (2), align the holes, install 4pc M10*120 outer hexagon bolt (8) and 4pc M10 lock nut (9), and tighten the bolts.

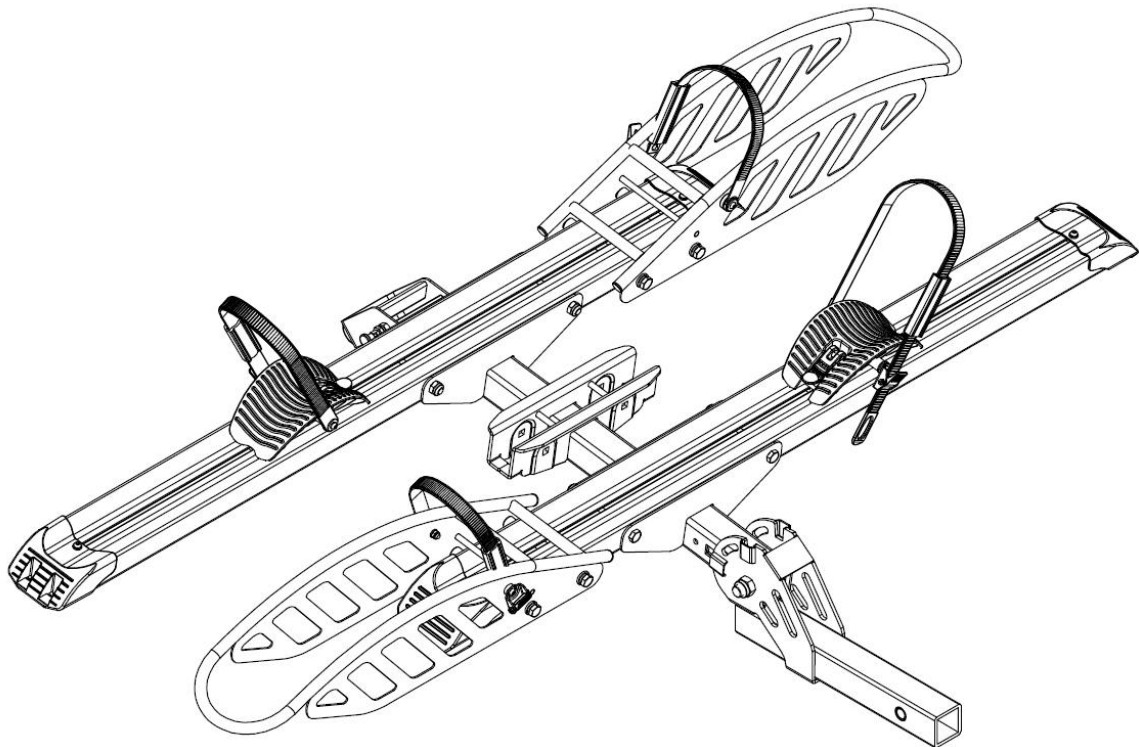
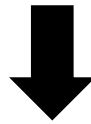
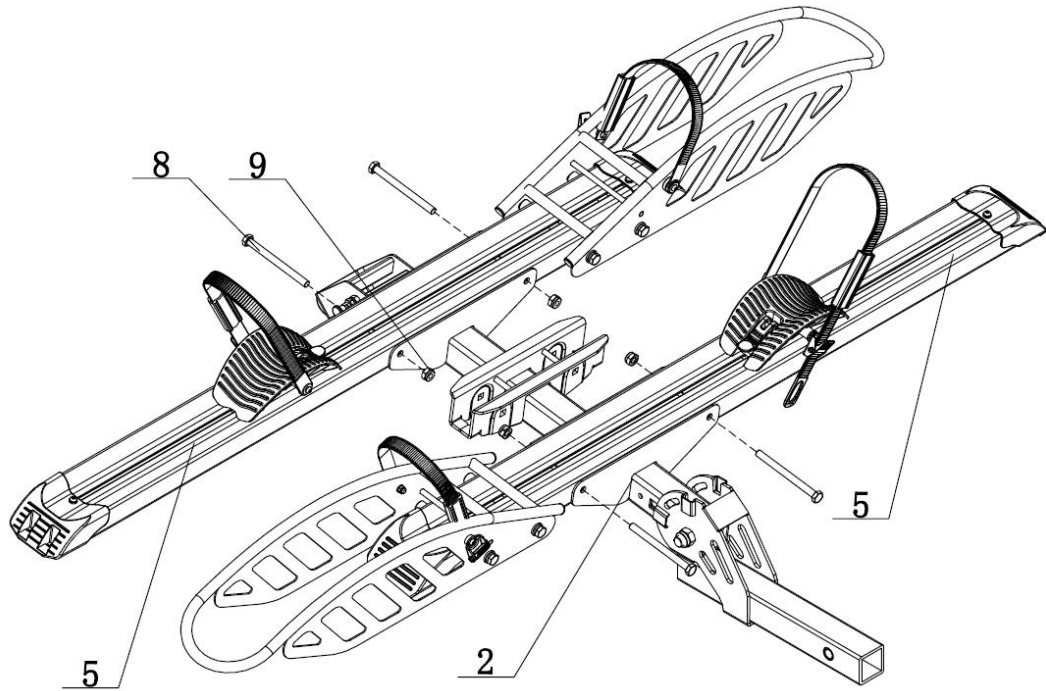

Step 4: Insert Middle Support Tube (10) into the base of Bottom Fixing Bracket (2), at the same time, insert the half round gasket (17) from the bottom up to the middle of the square tube and the bottom

plate boss to separate, then fix them with M10x60 Bolt (11) and M10 Lock Nut (9).

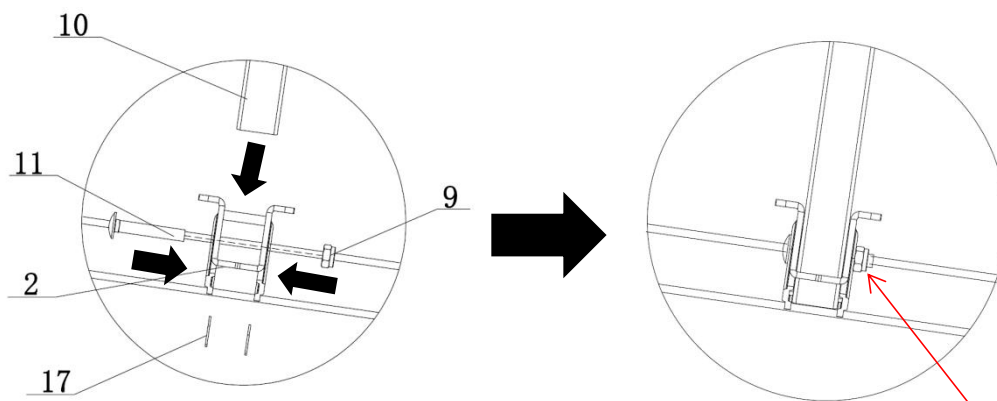
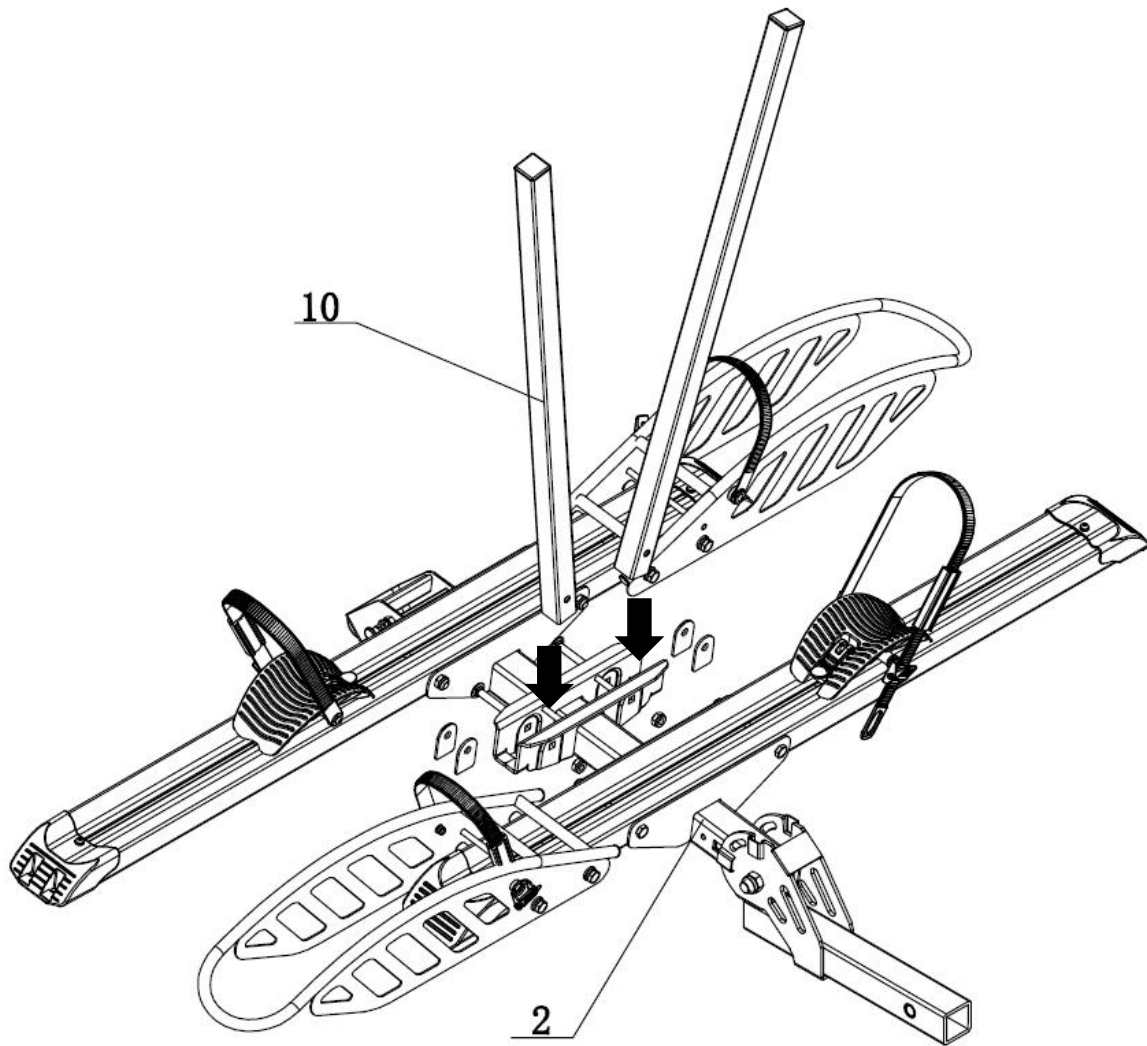

Here it is necessary to reach a torque of 50Nm so that the square tube does not shake.

Step 5: Install the Adjustable Block (12) to the Middle Support Tube (10), then tighten the knob from the Adjustable Block (12).

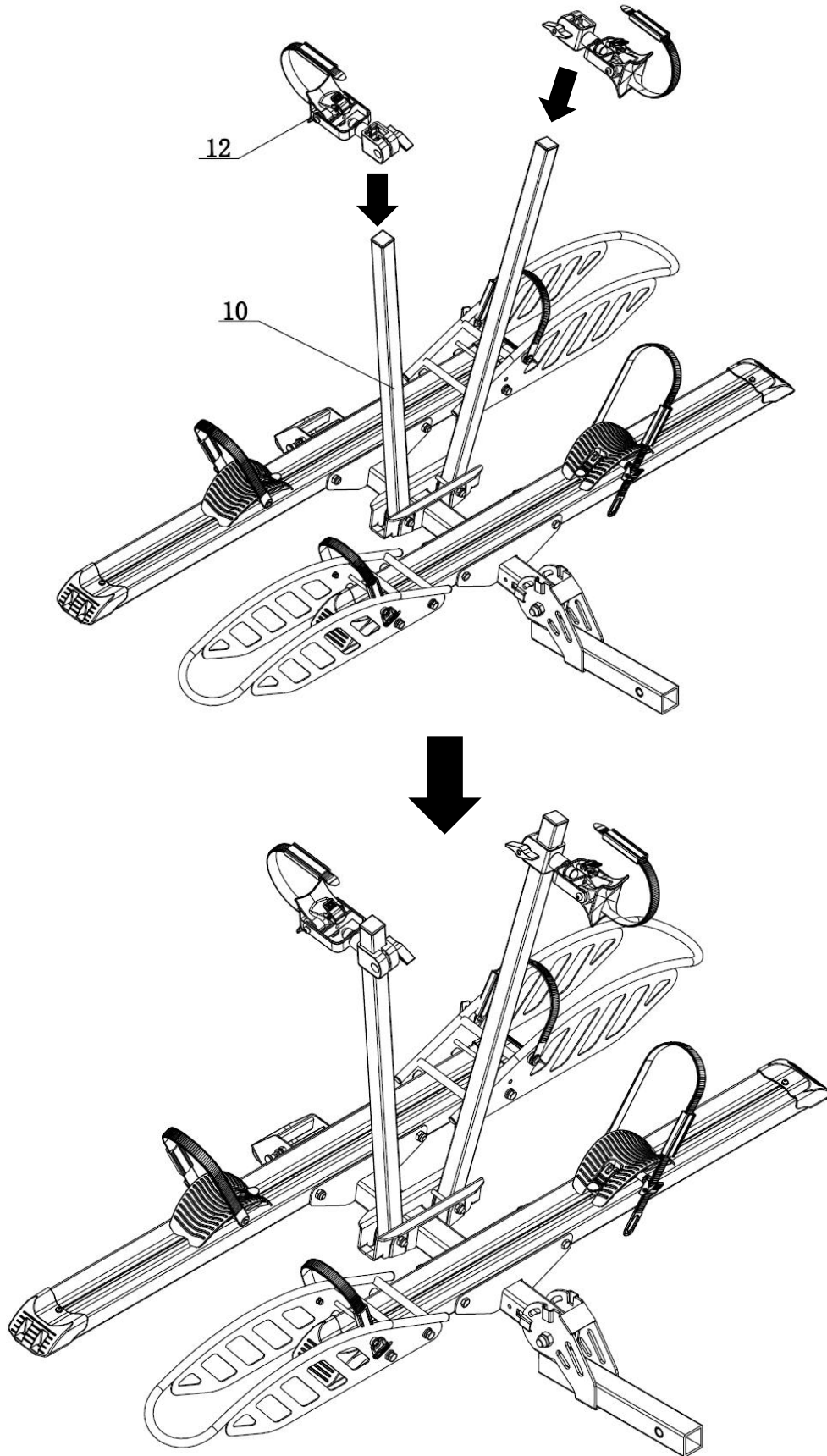

Step6: Align the holes of the folding tube with the holes on the vehicle's 2" hitch receiver, then connect the two parts as shown below. Place an M16 shockproof bolt (13), through the $\phi 16$ Spring Washer (14), $\phi 16$ Flat Washer (15) and the aligned holes. Secure the bolt in place with the 3.8 pin (16), making sure to

place the pin through the holes on the bolt.

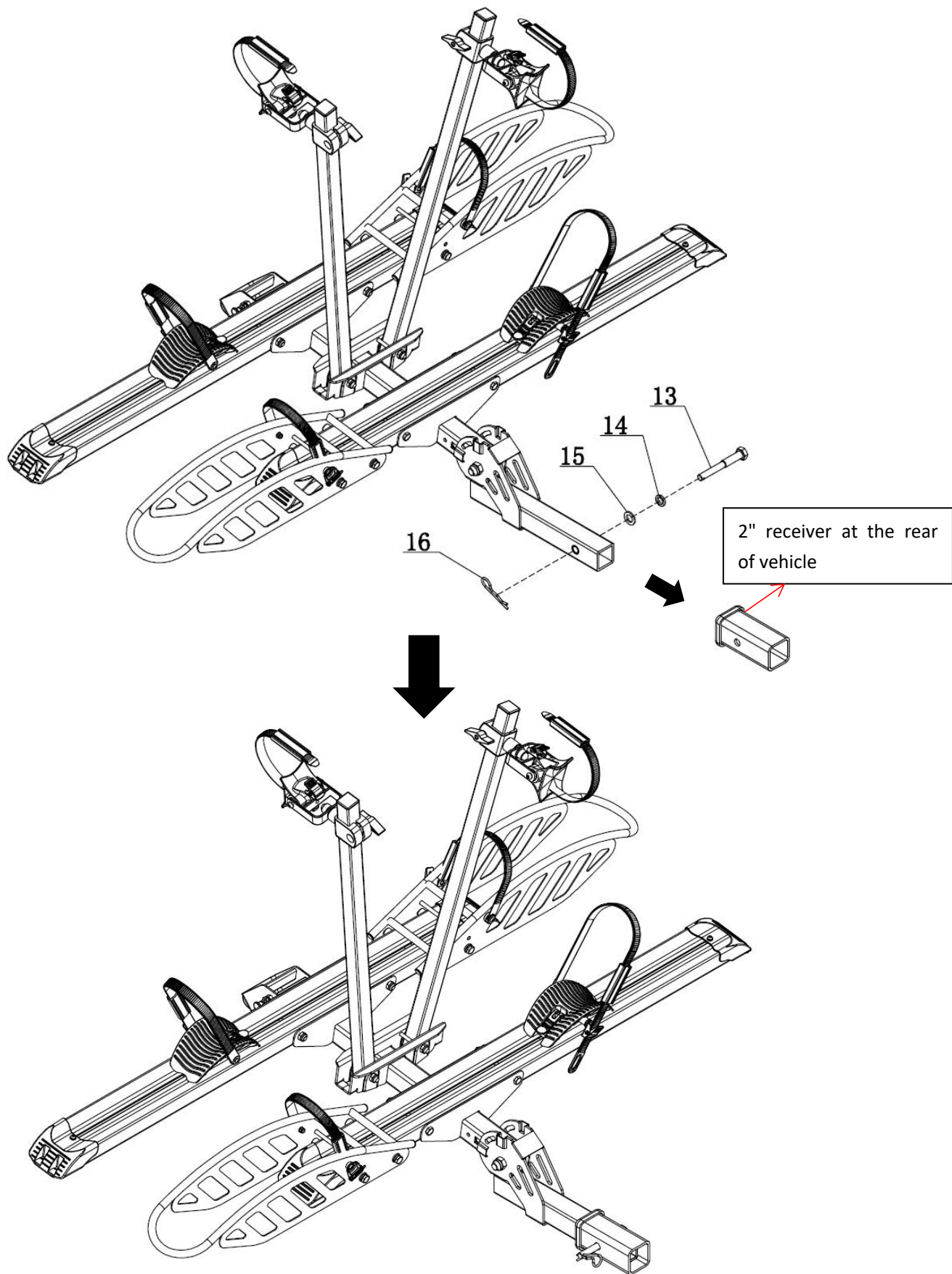

Bike Installation Instructions

STEP1: Turn the Middle Support Tube (10) to horizontal and remove the Connecting block (12) on which the first bicycle is mounted.

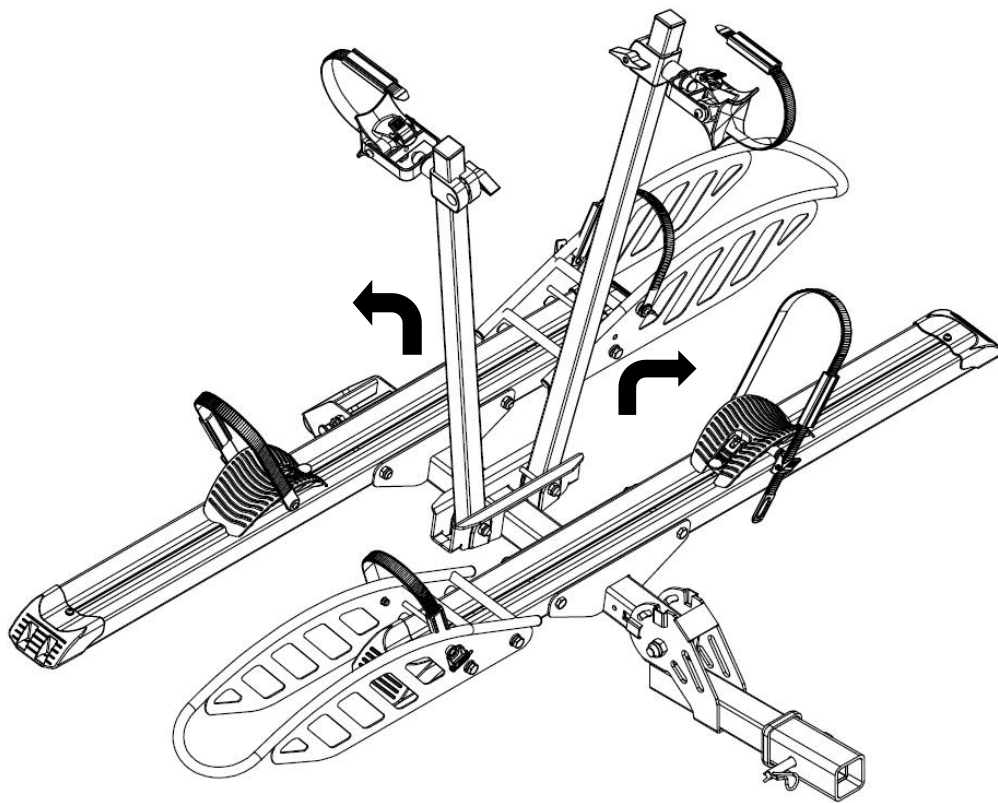

Note: The Connecting block (12) needs to be removed when installing the first bicycle to avoid interference when placing the bicycle.

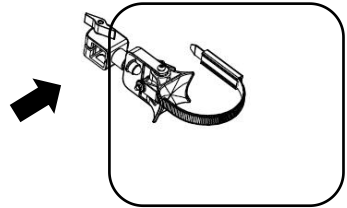
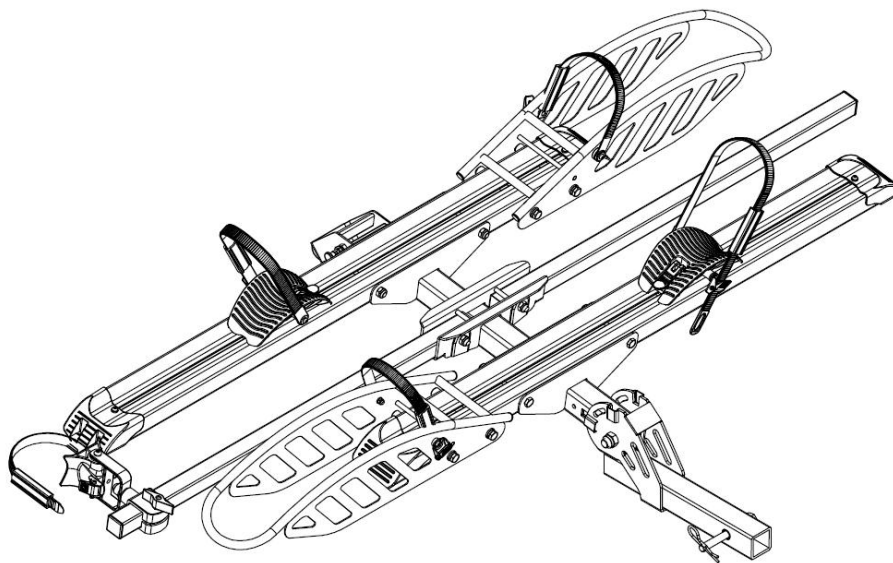
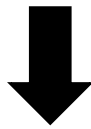

STEP2:

(1). Place the 1st bike to the Crossbeam (5) which is close to vehicle's hitch receiver.

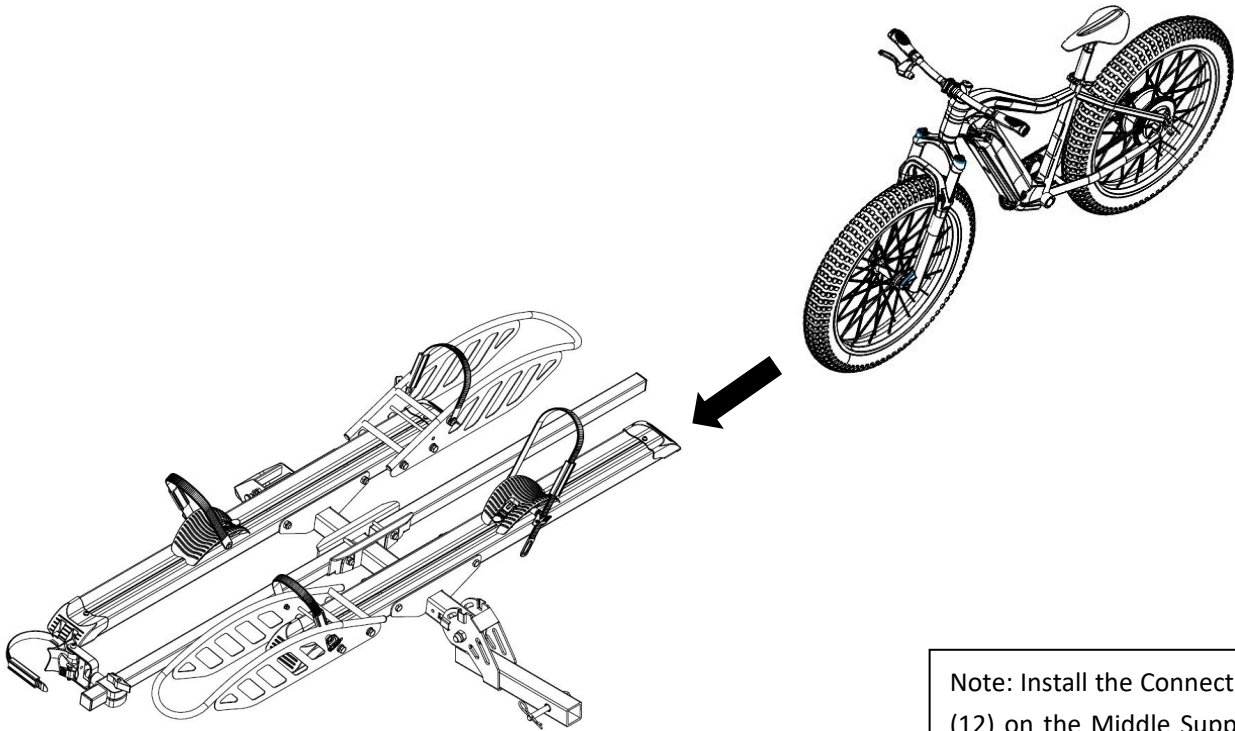

Note: Install the Connecting block (12) on the Middle Support Tube (10) after installing the first bike

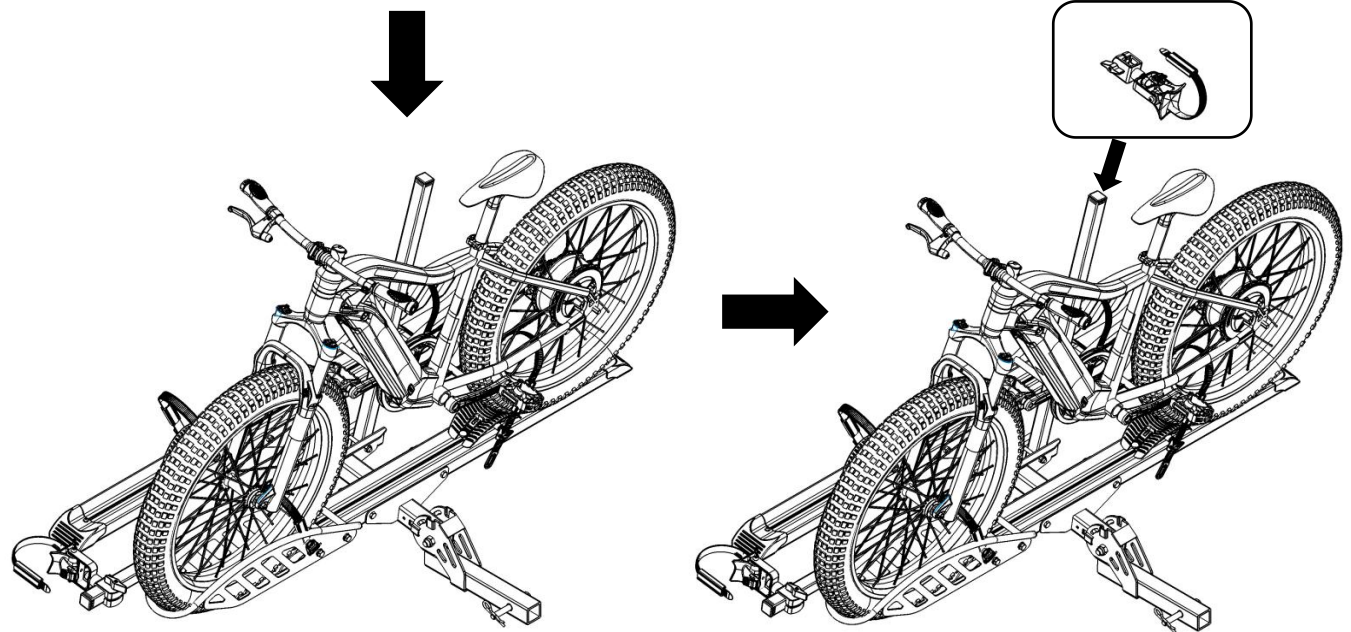

(2). Use the straps from the Front Wheel Holder (6), Crossbeam (5) and Middle Support Tube (10) to fix bike.

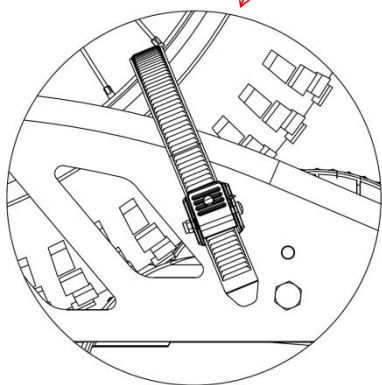
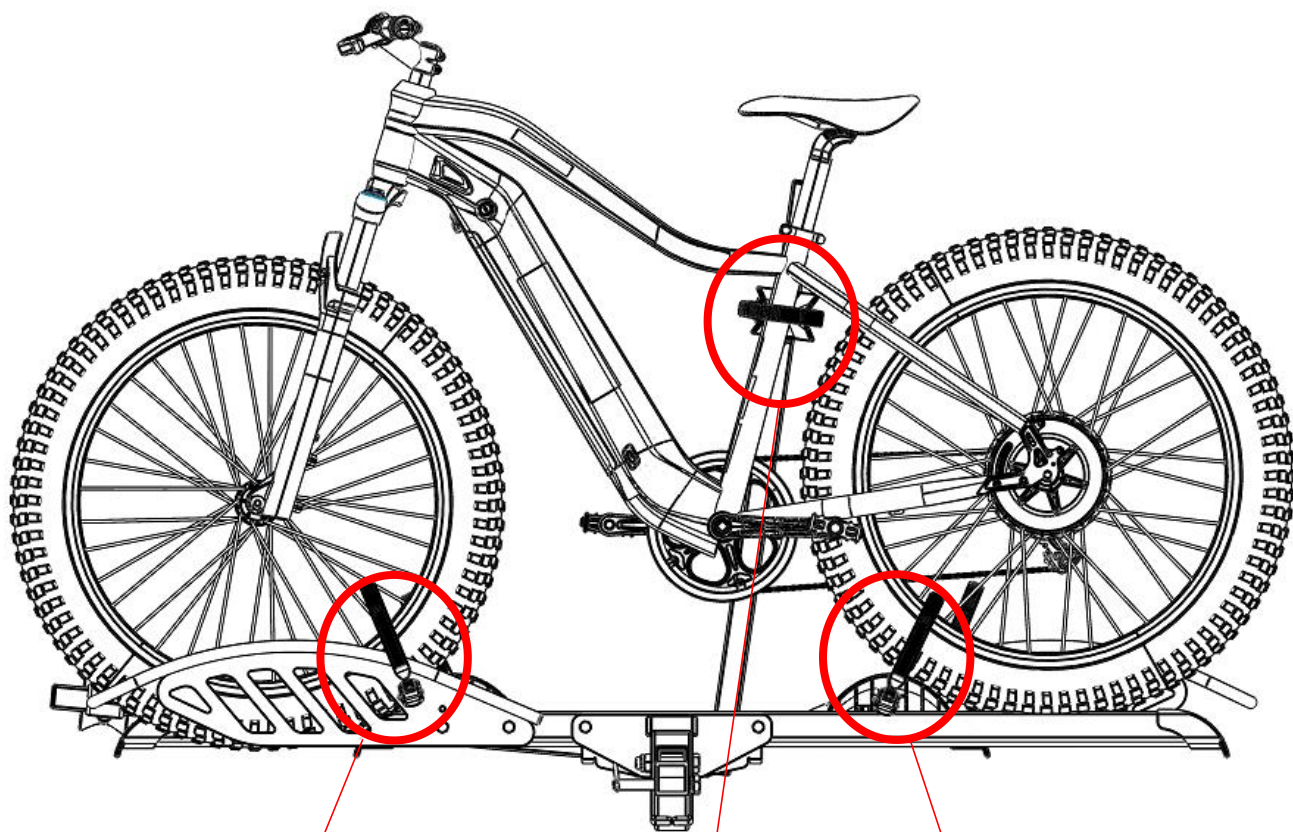

Note: Tighten the straps from the Front Wheel Holder.

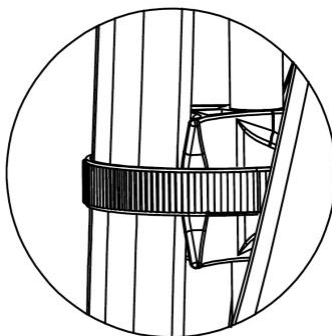

Note: Tighten the straps from the Adjustable Block.

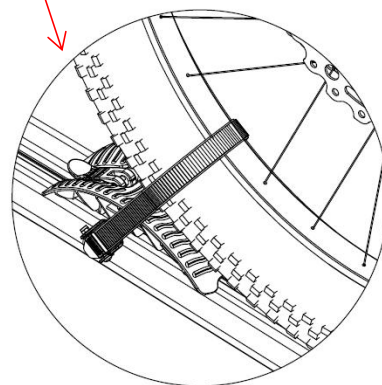

Note: The rear tire fixing seat needs to be placed in front of the rear wheel.

When the bike's tire is against the wheel cradle, press down the button on the wheel cradle to secure it firmly.

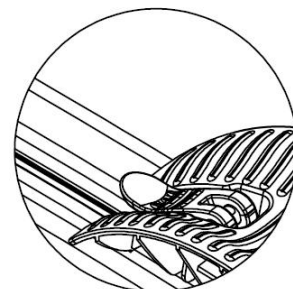
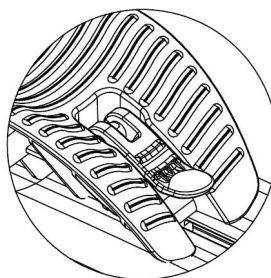

2A. How to secure the wheel cradle.

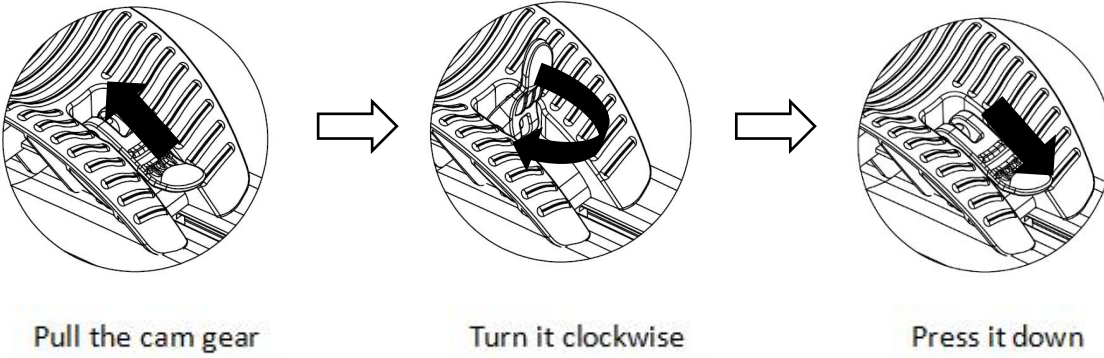

2B. How to release the wheel cradle.

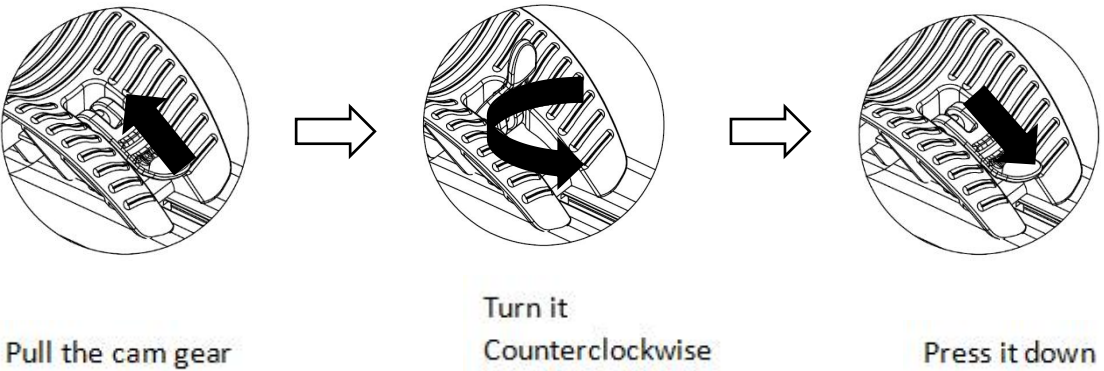

(3) Repeat (1) and (2) for placing the 2nd bike.

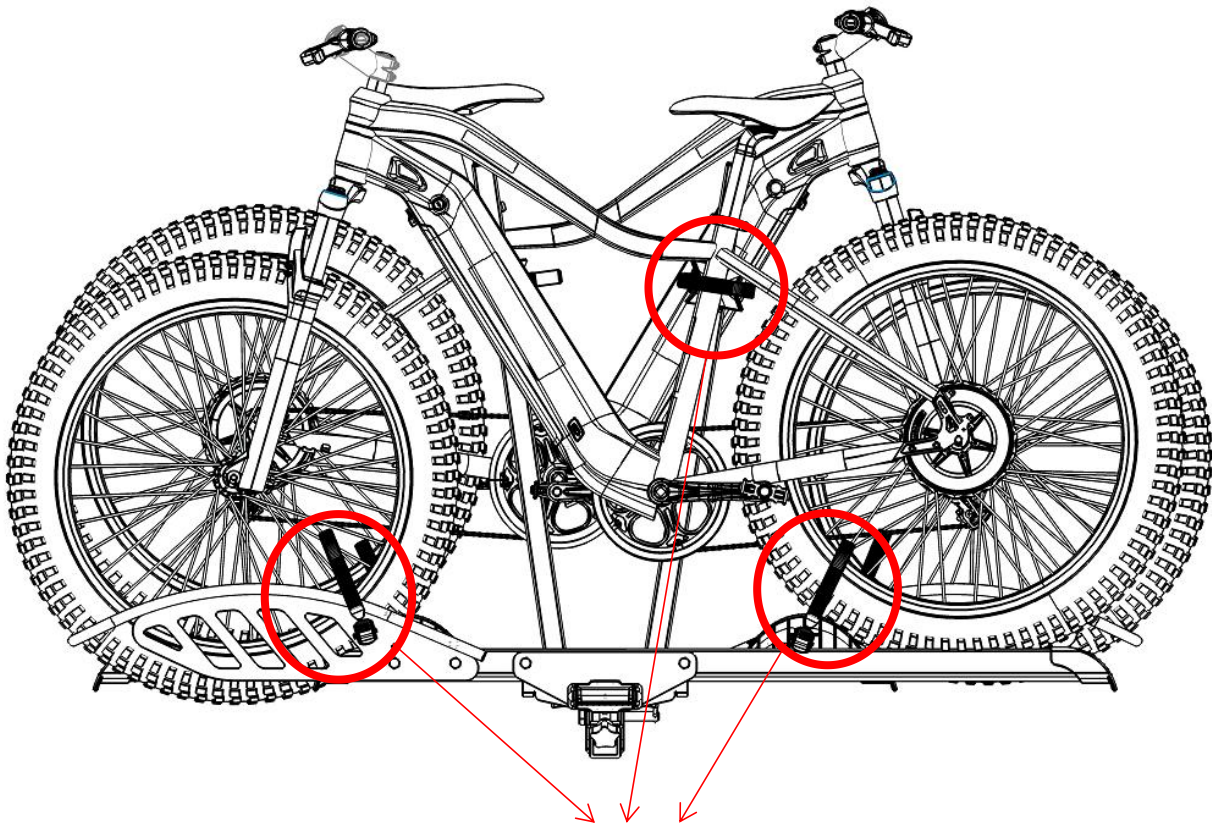

Note: Tighten the straps here.

Folding Status

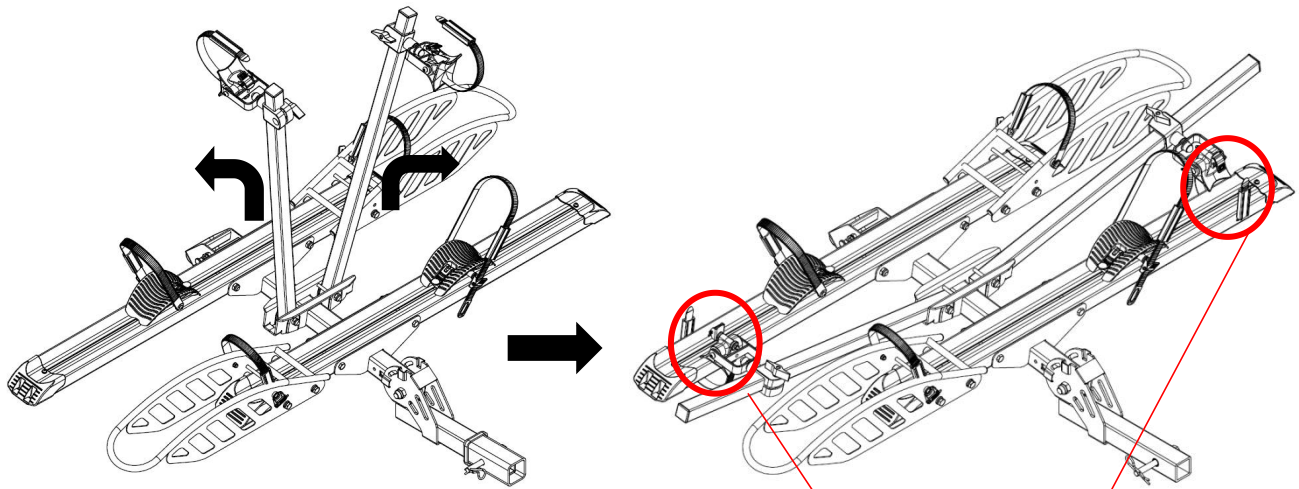

Using the straps from Adjustable Block to fix the Crossbeam.

Note: Before pulling the handle to fold it needs to be pull out the limit pin on the side and rotate it 90°.

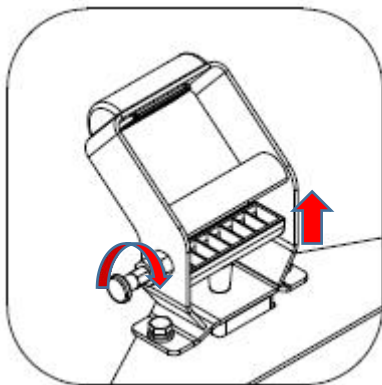

Handle

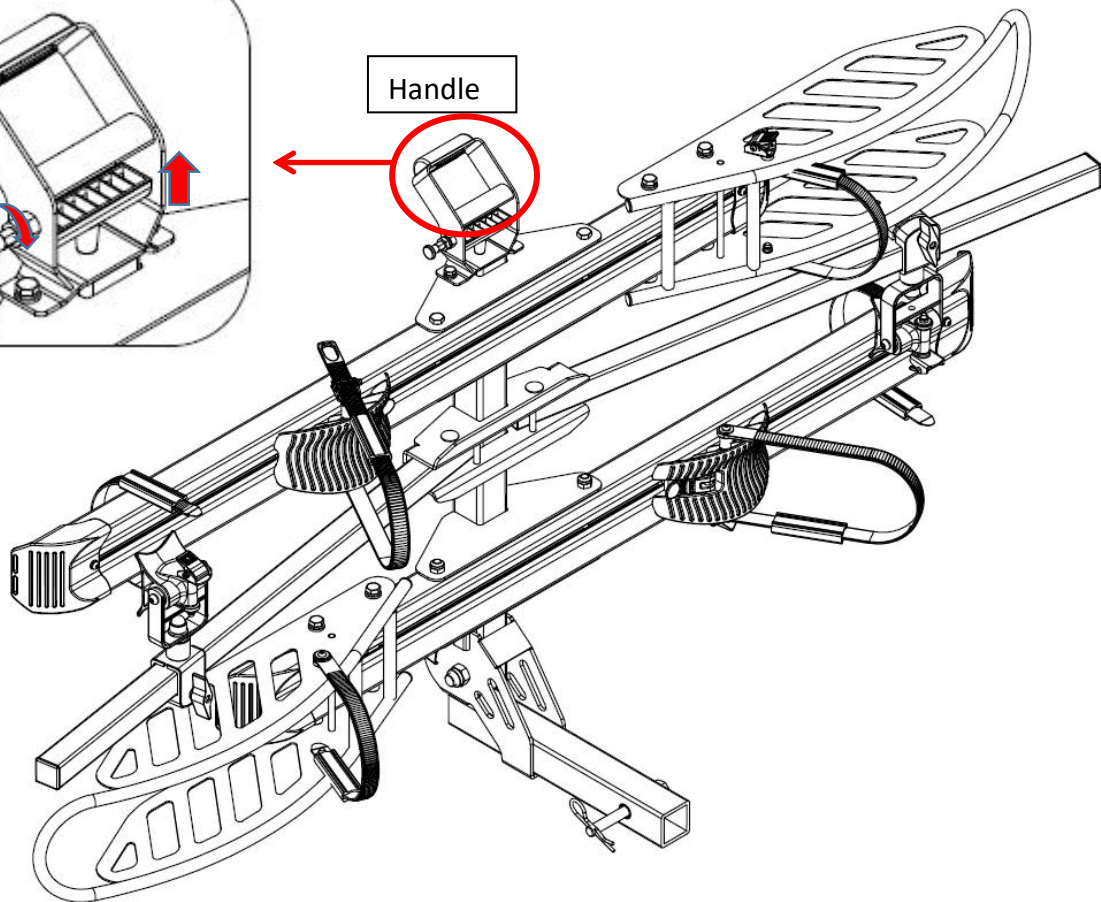

Pull the handle in the direction the arrow shows to fold the bike rack vertically, or to unfold it so it sits flat. The bike rack will automatically stop when it reaches a fixed position