



*Aluminum Hitch-Mounted
Bike Carrier*

Aluminum Hitch-Mounted Bike Carrier



Item# 10104098/10104098A

Technical Specifications

Property	Specification
Length	57.5"
Width	44.6"
Height	43.5"
Maximum Weight Capacity	200LBS*



Aluminum Hitch-Mounted Bike Carrier

Diagram

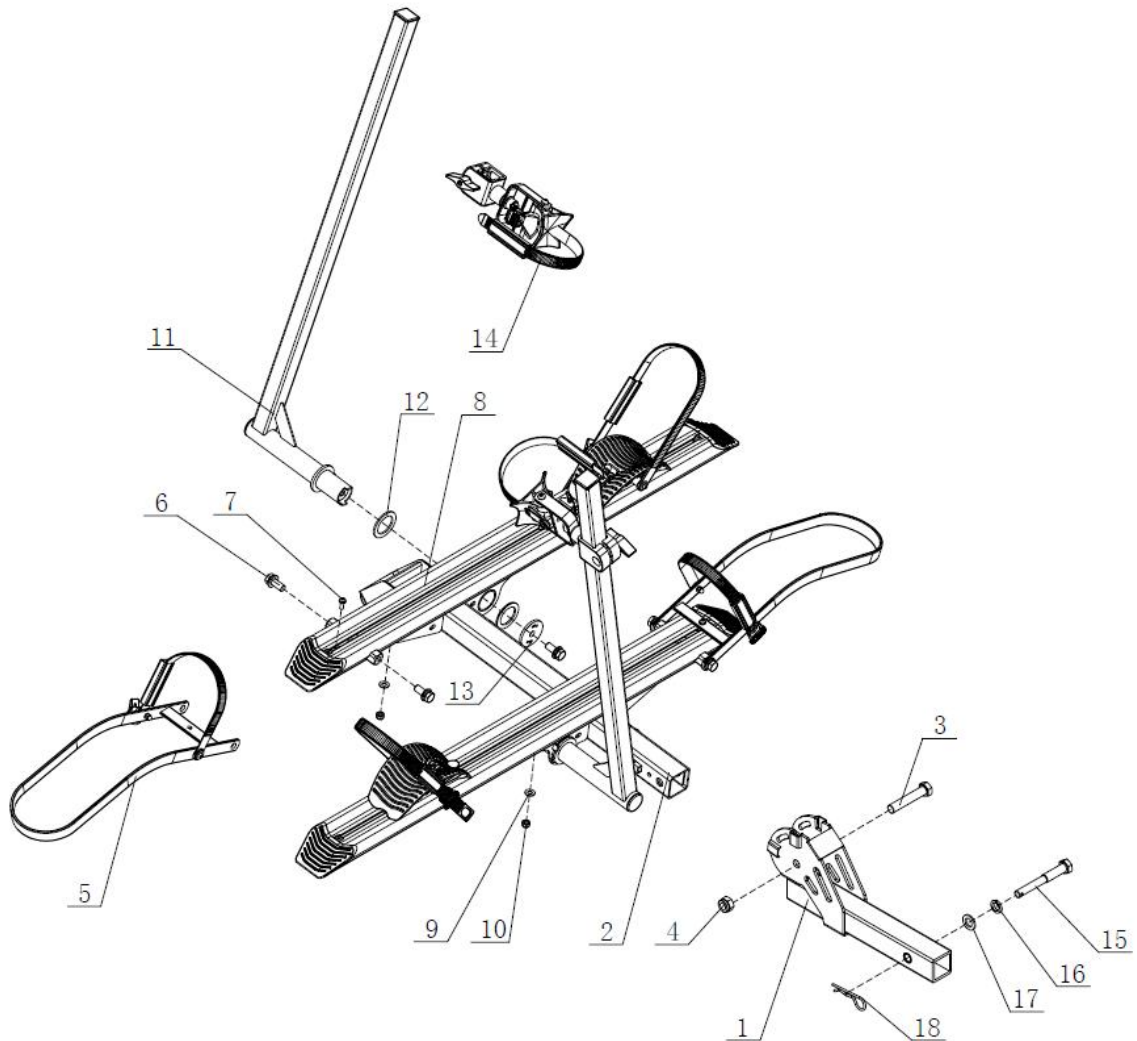

Parts List

Part #	Description	Qty	Part #	Description	Qty
1	Folding Connector	1	10	M8 Lock Nut	4
2	Supporting Tube	1	11	Vertical Bar	2
3	M16x85 Hexagon Bolt	1	12	Plastic Gasket	4
4	M16 Lock Nut	1	13	Circular Gasket	2
5	Front Wheel Fixing Base	2	14	Adjusting Support Assembly	2
6	M12x30 Screw	6	15	M16 Shockproof Bolt	1
7	M6x25 Screw	2	16	φ16 Spring Washer	1
8	crossbeam	2	17	φ16 Flat Washer	1
9	M8 Flat Washer	4	18	φ3.8 Pin	1



Aluminum Hitch-Mounted Bike Carrier

⚠ WARNING ⚠

- Do not overload beyond bike rack's weight capacity of 200 lbs.
- Do not carry more than 2 bikes on the carrier.
- The bike rack is not intended for transporting humans or animals.
- If you are planning to load only one bike, it is recommended to place it in the position closest to the vehicle.
- All bikes must be secured properly before operating the vehicle.
- Make sure the front of the bike(s), when mounted, are at or above the bottom of the bumper to avoid damage to the bike(s).
- Do not carry flammable items on the bike rack.
- If using the bike rack to transport electric bicycles, please remove the batteries from the bicycles prior to transporting. This will help reduce the weight supported by the carrier.
- During long trips, frequently check the straps and bike position, especially if traveling on rough terrain.
- Please do not make alterations to the product, as it can pose potential hazards to your safety.
- Failure to heed these warnings may result in personal injury and/or property damage.
- To prevent serious injury or death, inspect the bike rack for any signs of wear, corrosion and fatigue before each use. Do not use the bicycle rack if parts are bent, broken, deformed or missing. If parts are bent, broken, damaged or missing, remove the rack from your vehicle before operating the vehicle.

Recommended Tools for Assembly (Not Included)



Monkey Wrench (1pc)
Size=300mm



Open Wrench (1pc)
Size=13mm



Open Wrench (1pc)
Size=17mm



Open Wrench (1pc)
Size=24mm



4mm Allen Wrench



Aluminum Hitch-Mounted Bike Carrier

Assembly Instructions

Step 1: Align the holes on the supporting tube (2) and folding connector (1), then connect the two parts by inserting the M16*85 hexagon bolt (3) through the holes. Secure the bolt in place by screwing on the M16 lock nut (4). CAUTION: To ensure the rack will fold smoothly, do not overtighten the lock nut. (We recommend tightening to 80% tightness.)

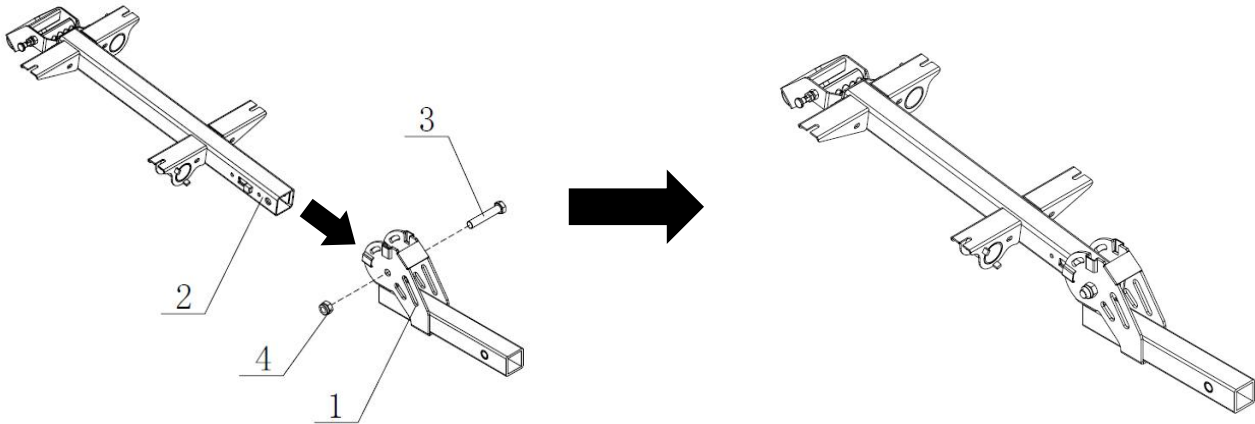

Step 2: Align the front wheel fixing base (5) with the hole position of the beam assembly (8), install M12*30 screws (6) on both sides, and install M6*25 screws on the top, and ensure that they are tightened.

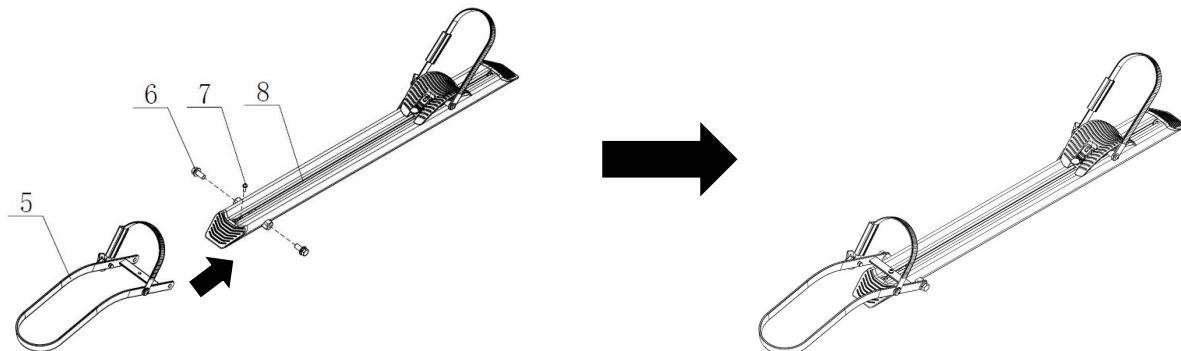

Step 3: Install a crossbeam (8) on the supporting tube (2) closest to the folding connector, making sure the crossbeam is centered on the supporting tube. Locate the M8*20 carriage bolts in the crossbeam and align each of them with a slot in the supporting tube. Place $\phi 8$ Flat Washers (9) below the supporting tube and secure the bolt and washer in place with M8 lock nuts (10). Be sure to fully tighten the lock nut.



Aluminum Hitch-Mounted Bike Carrier

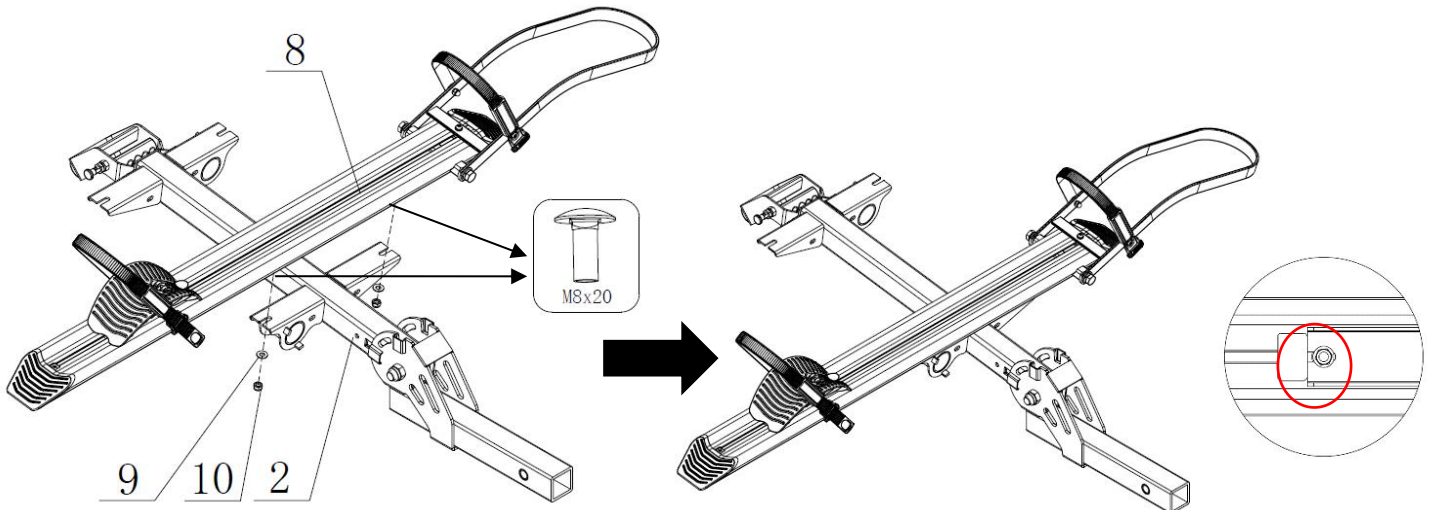

Two M8*20 carriage bolts are pre-installed in the crossbeam.

Note: The rectangular plate at the bottom of the beam assembly needs to be pushed to assembly 2 to ensure that the beam assembly is centered.

Step 4: Install the other crossbeam (8) on the supporting tube (2), farthest from the folding connector. Follow the steps outlined in Step 2.

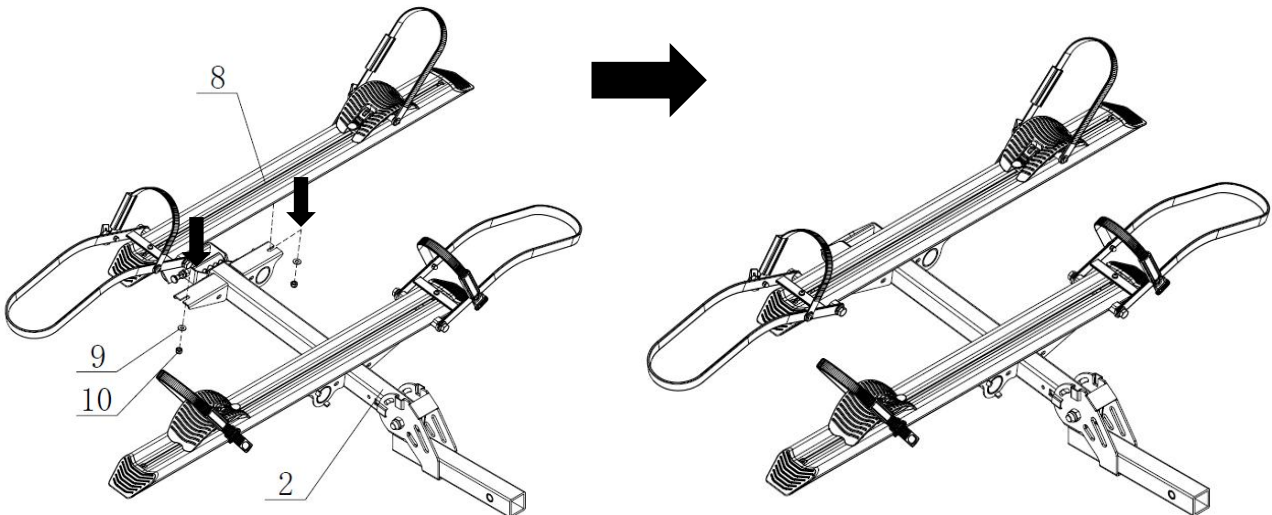

Step 5: Align the adjusting tube assembly (11) with the round hole in the middle of the assembly (2), adjust the tube assembly (11), plastic round gasket (12), Supporting Tube (2), plastic round gasket (12), open round gasket (13), M12x30 Screw (6) in order, and tighten them. Note: the installation direction of the adjusting tube assembly (11) is as shown in the figure below.



Aluminum Hitch-Mounted Bike Carrier

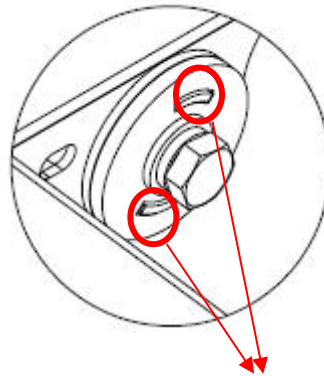
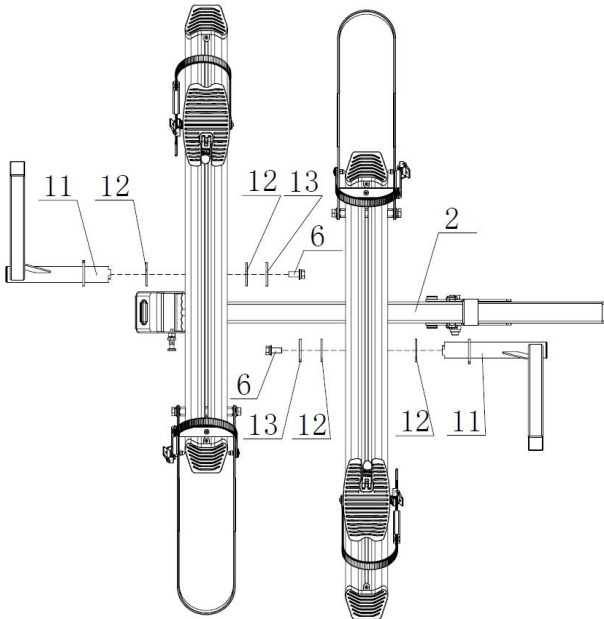

Note: The open circular gasket (13) should be assembled flush with the two bosses of the adjusting tube assembly (11).

The boss is put into the hole, and the bolt torque is 50Nm, to ensure that the adjusting lever in the whole process of the movement of the existence of damping state, will not automatically fall, gravity collision.

Note: The convex head with convex disc in assembly (11) shall be installed in the middle of two rectangular bosses in assembly 2 and on the outside.

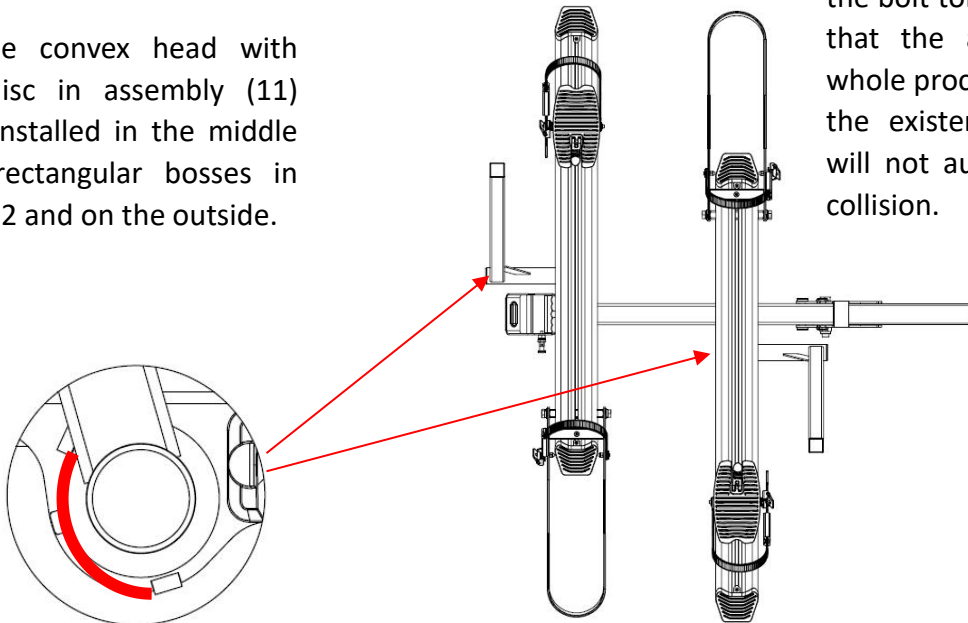

Step 6: Insert the adjusting support assembly (14) into the adjusting tube assembly (11).

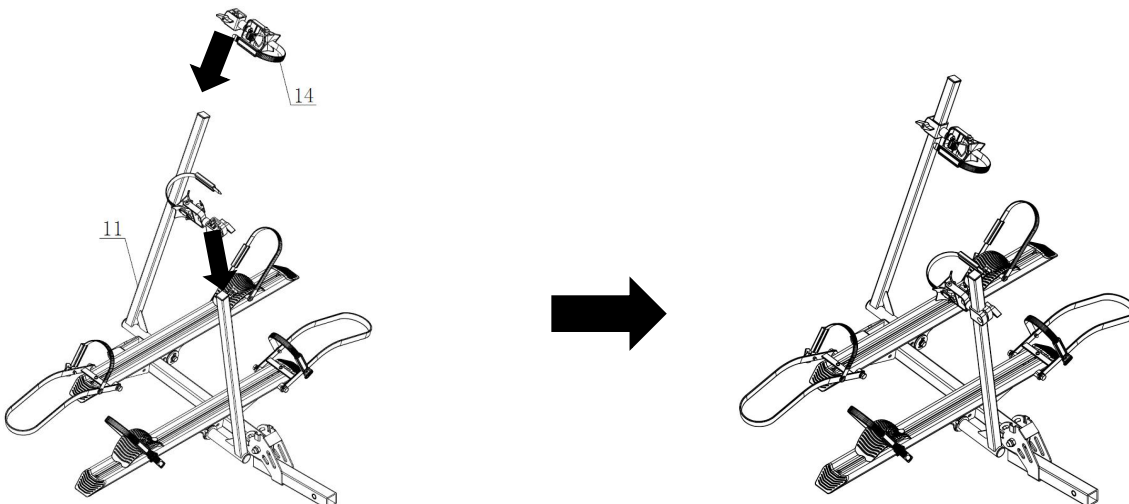



Aluminum Hitch-Mounted Bike Carrier

Step 8: Align the holes of the folding tube with the holes on the vehicle's 2" hitch receiver, then connect the two parts as shown below. Place an M16 shockproof bolt (15), through the ϕ 16 Spring Washer (16), ϕ 16 Flat Washer (17) and the aligned holes. Secure the bolt in place with the 3.8 pin (18), making sure to place the pin through the holes on the bolt.

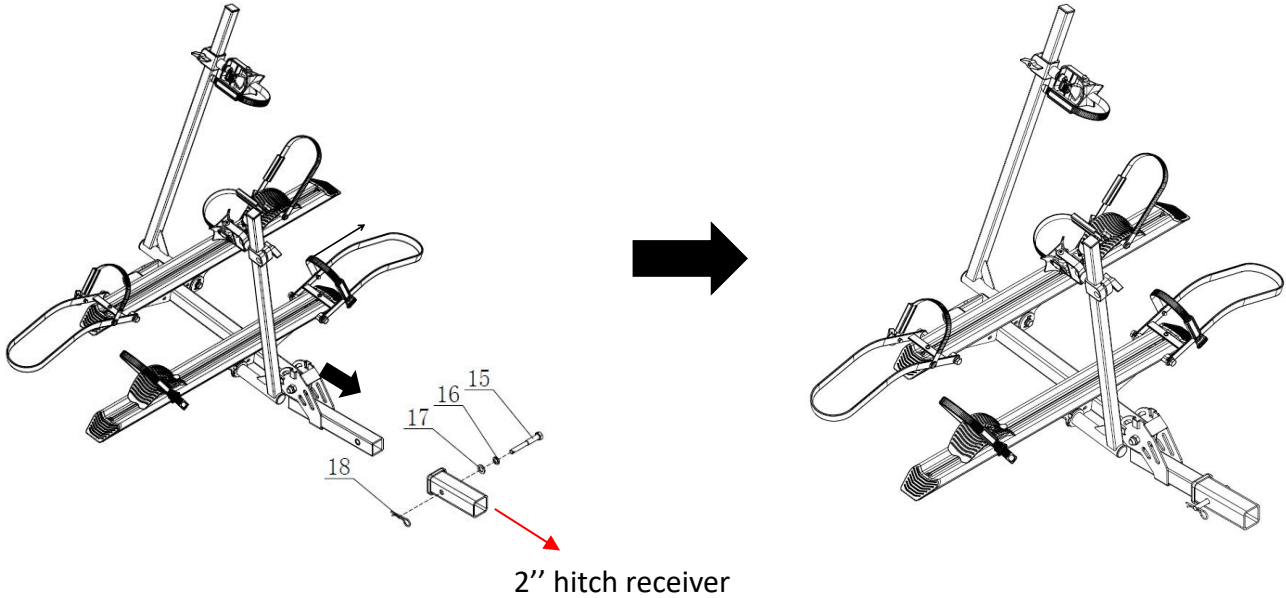



Aluminum Hitch-Mounted Bike Carrier

Bike Installation Instructions

STEP 1: First place the adjusting tube assemblies on both sides of the bicycle frame horizontally.

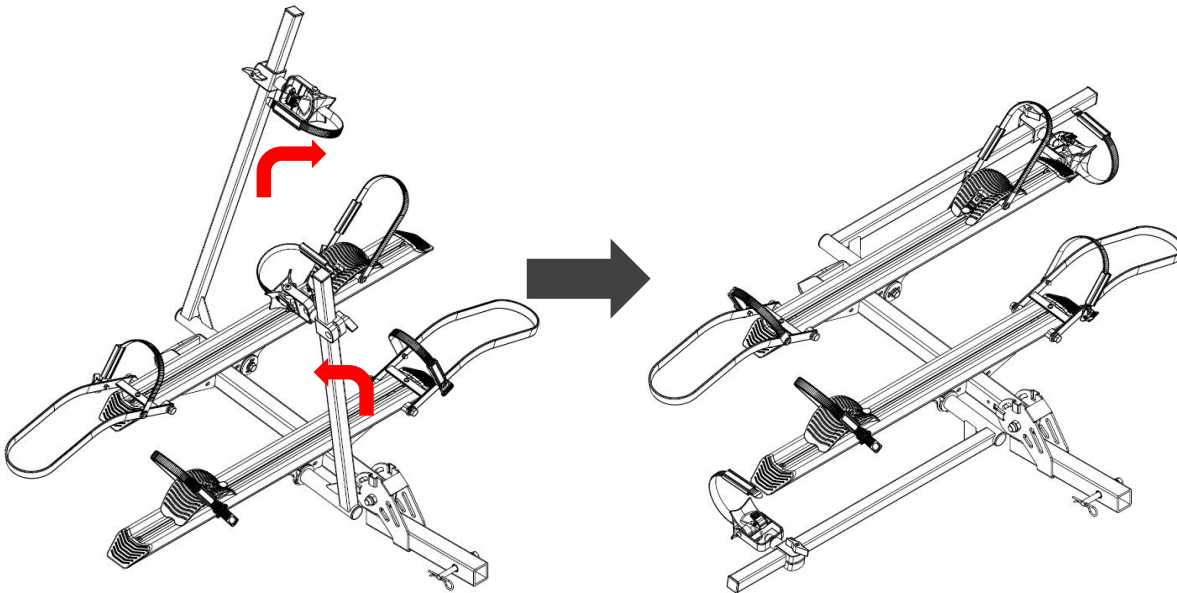

STEP 2: Place the first bicycle to the nearest position to the car, rotate the adjusting tube assembly, place it at the bicycle tripod, tighten it with a buckle tension belt, and finally fix the front and rear wheels with the buckle tension belt at the bottom.

Fix it on the tripod area with the adjusting support assembly and tighten the knob.

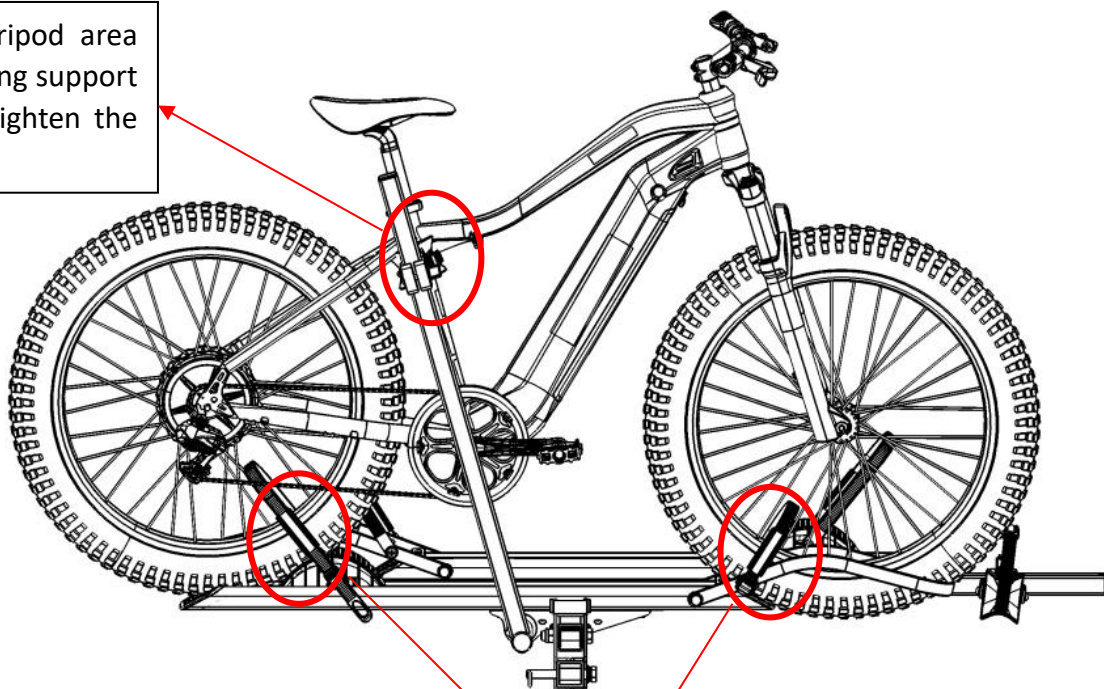

Tighten and fix with buckle tension strap



Aluminum Hitch-Mounted Bike Carrier

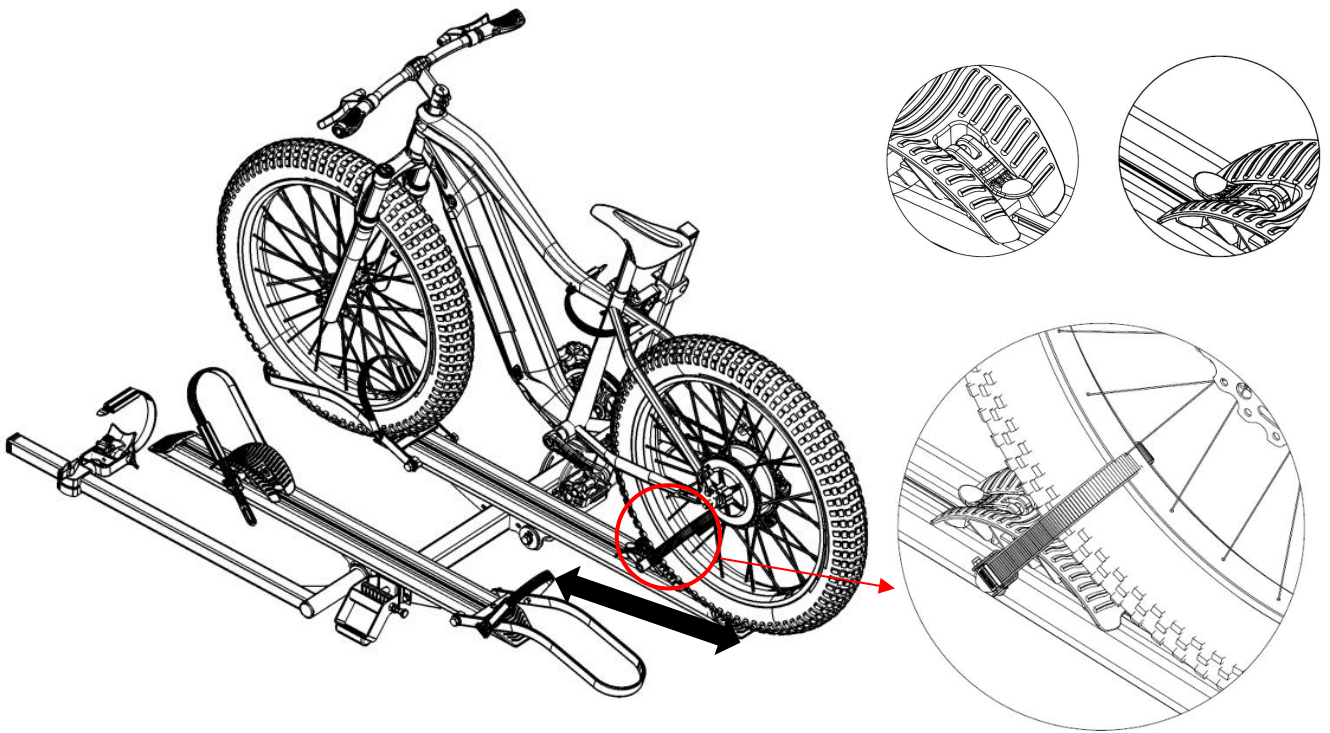

When the bike's tire is against the wheel cradle, press down the button on the wheel cradle to secure it firmly.

Note: The rear tire fixing seat needs to be placed in front of the rear wheel.

Adjust the wheel cradles based on the distance of the bicycle's wheel base, ensuring the cradles are wide enough apart to support the bicycle tires. To move the cradles, open the cam gear (Step 2B) and slide them along the crossbeam. Close the cam gear (Step 2A) to lock the cradle in place.

2A. How to secure the wheel cradle.

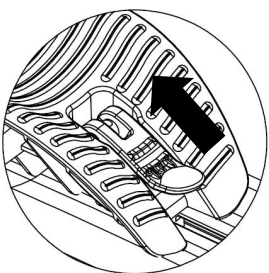

Pull the cam gear

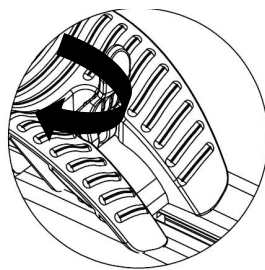

Turn it clockwise

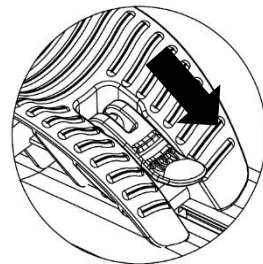

Press it down

2B. How to release the wheel cradle.

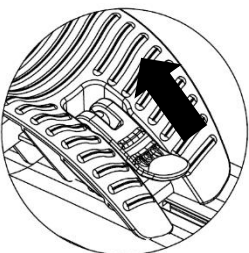

Pull the cam gear

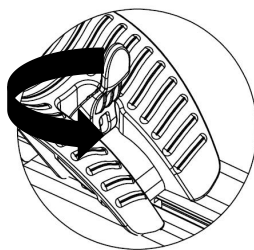

Turn it anticlockwise

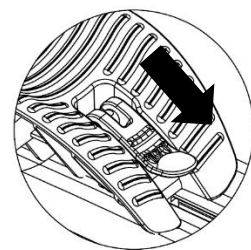

Press it down



Aluminum Hitch-Mounted Bike Carrier

STEP 3: Repeat the steps of installing the first bicycle to install the second bicycle.

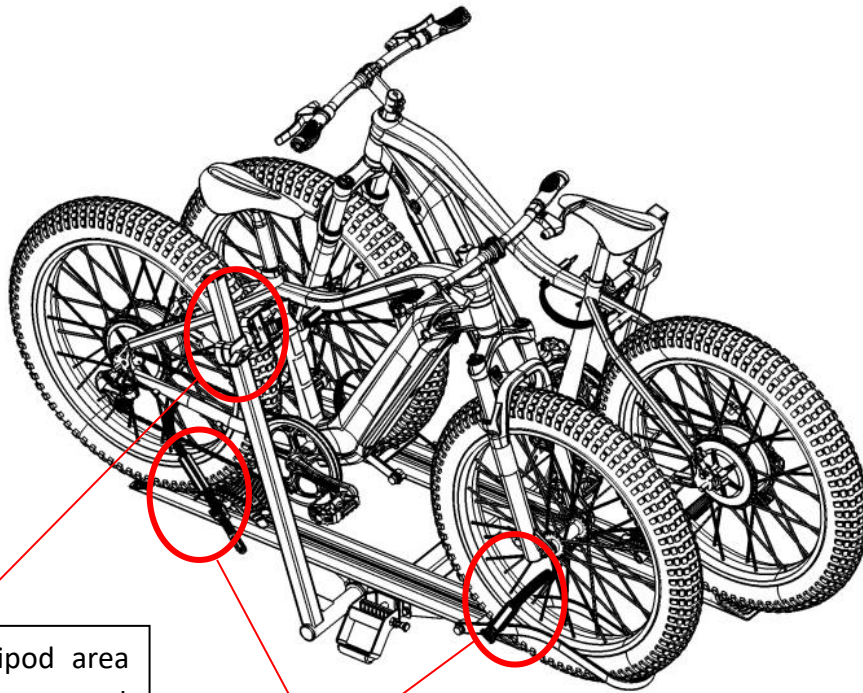

Fix it on the tripod area with the adjusting support assembly and tighten the knob.

Tighten and fix with buckle tension strap.



Aluminum Hitch-Mounted Bike Carrier

Folding Status

STEP 1: First rotate the adjusting tube assemblies on both sides of the bicycle frame horizontally (as shown in Figure 1), and then fix the adjusting support assembly on the beam assembly with a tension strap (as shown in Figure 2).

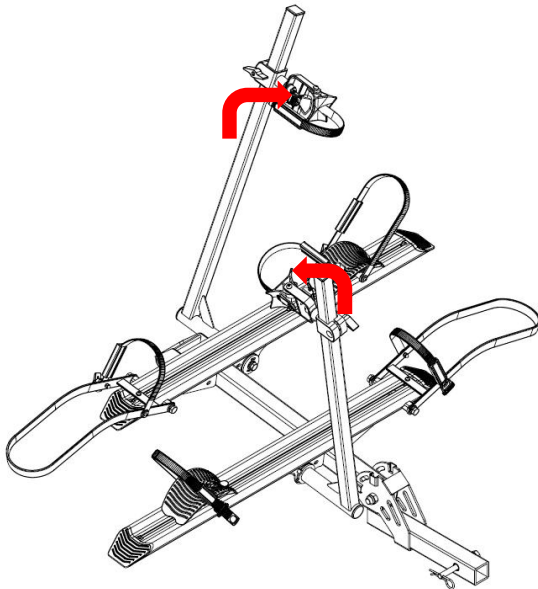

FIG 1

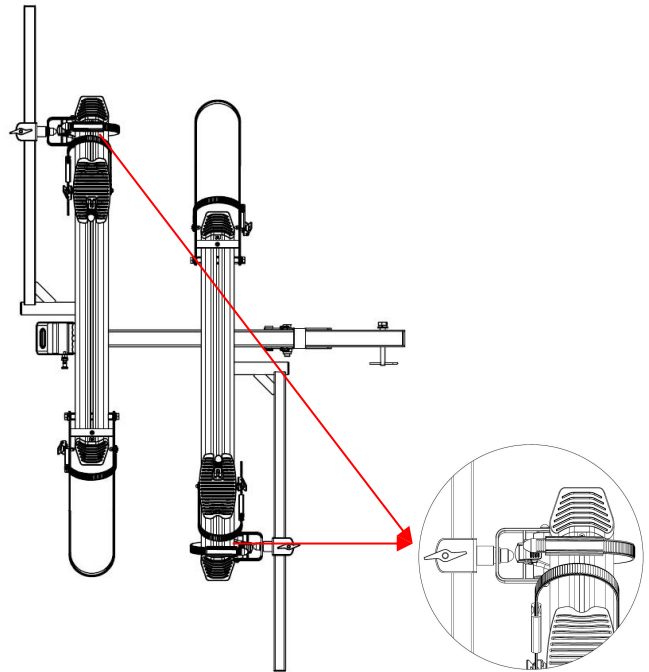

FIG 2

STEP 2: Pull the handle in the direction the arrow shows to fold the bike rack vertically, or to unfold it so it sits flat. The bike rack will automatically stop when it reaches a fixed position.

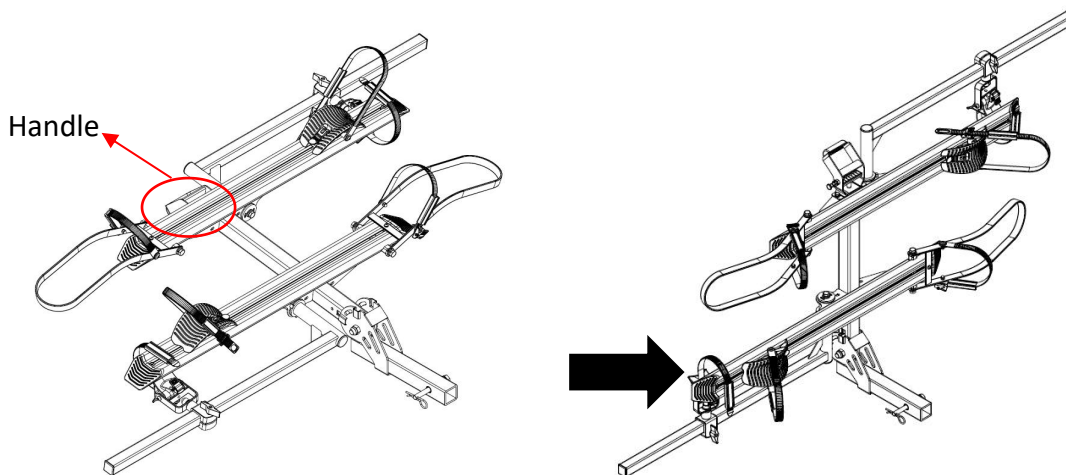
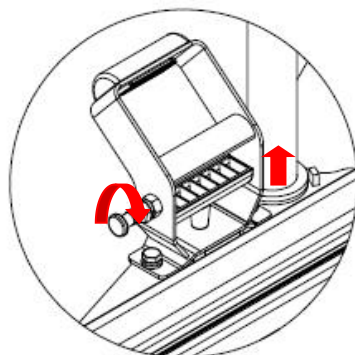

FIG 3

FIG 4



Note: Before pulling the handle to fold it needs to be pull out the limit pin on the side and rotate it 90°.