

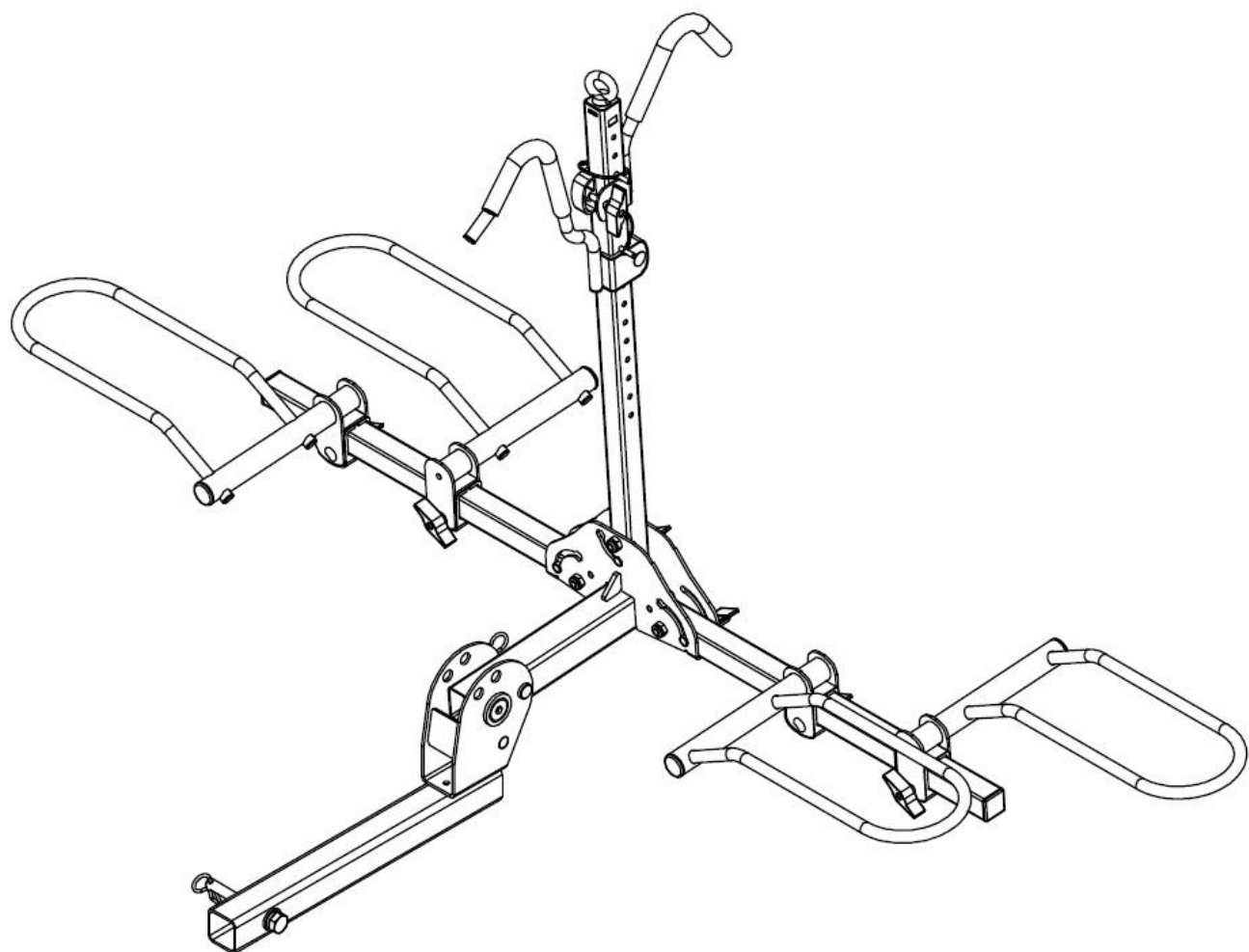

## PLATFORM BIKE RACK-2 BIKE



## WARNING

Read this manual thoroughly before installing and using your bike carrier. Failure to follow instructions could result in serious injury to person or property.

The bicycle carrier should not be used for TOWING or any pulling purpose.

The weight capacity of this carrier is 200 lbs.

DO NOT exceed the rated capacity of this bike carrier.

For use with Bikes that have tires less than 5 inches wide.

DO NOT use this bike carrier for transporting or carrying other items or materials besides bicycles.

Using the bike rack for rough off-road terrain is not recommended.

Not for use on off-road terrain.

**Read this owner's manual before using your bike rack. Familiarize yourself with the location and function of the controls and features. Save this manual for future reference.**

### Assembly Recommended Tools:



Monkey Wrench (1pc)  
Size=300mm



Open Wrench (1pc)  
Size=17mm



Open Wrench (1pc)  
Size=24mm



6# inner hexagon  
spanner (1pc)



10# inner hexagon spanner (1pc)

## Assembly Instructions

**STEP 1** Assemble the primary frame by connecting the Support Base Assembly (part #1) and (2) Horizontal Tubes (part #2) using (2) 5/16" knob, (4) 5/16" flat washer, (2) 5/16" spring washer, (2) 5/16" hexagon bolt, (2) M10 Bolt and (2) M10 Locknuts (parts #3, #4, #5, #6, #7 & #8). See FIG. 1

FIG 1

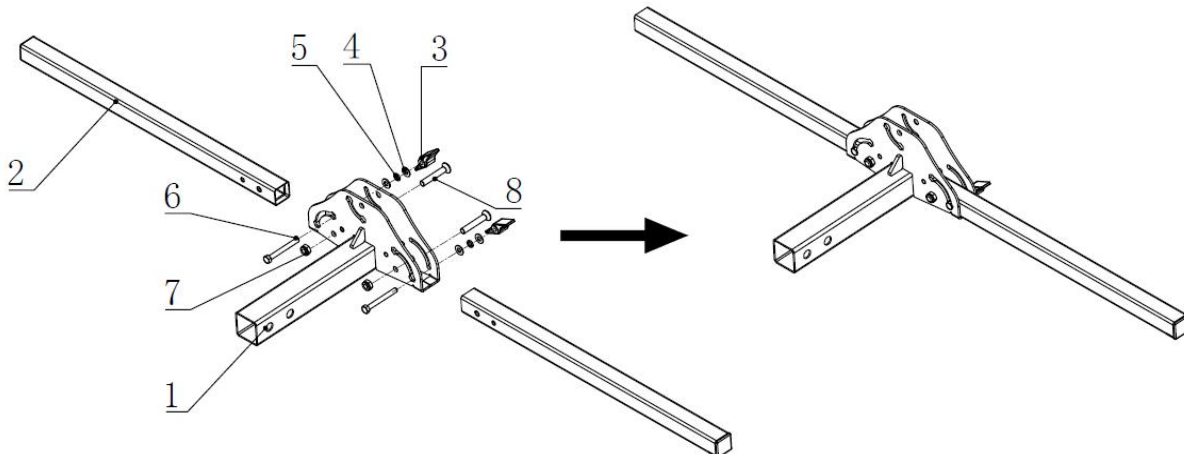

**STEP 2** Place Vertical Tube (part #9) into the Support Base Assembly by using M10 Bolt and M10 Locknut (parts #7 & #8). With the Vertical Tube in a vertical position, insert the 5/16" hexagon bolt (part #6), through the 5/16" flat washer (part #4), the 5/16" spring washer (part #5) and the 5/16" flat washer (part #4), tighten with 5/16" knob (part #3). See FIG. 2

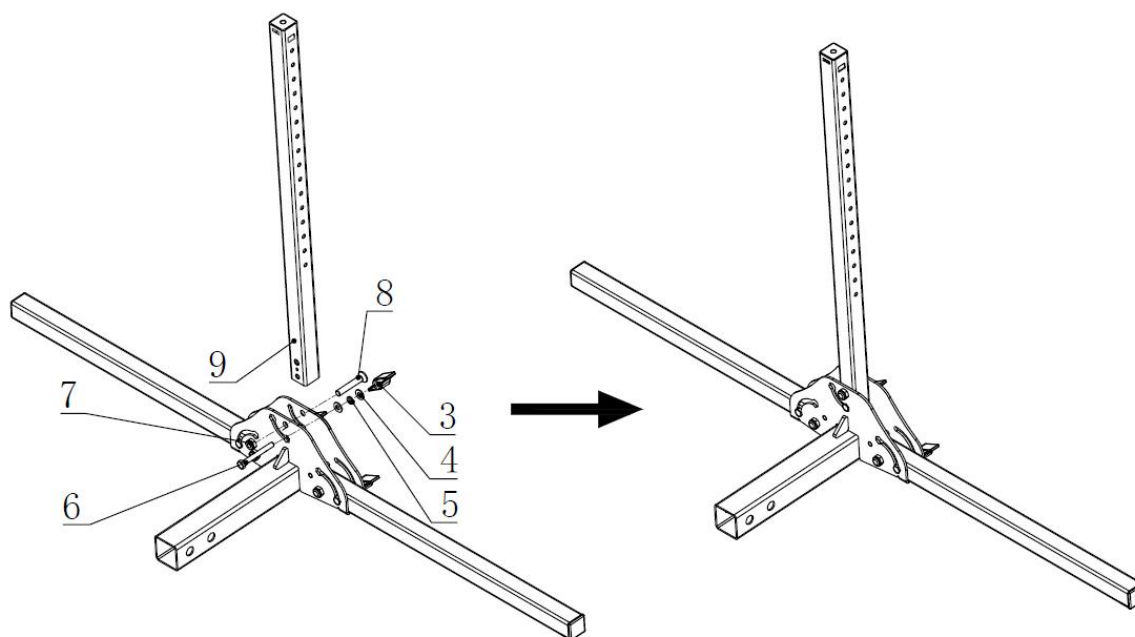
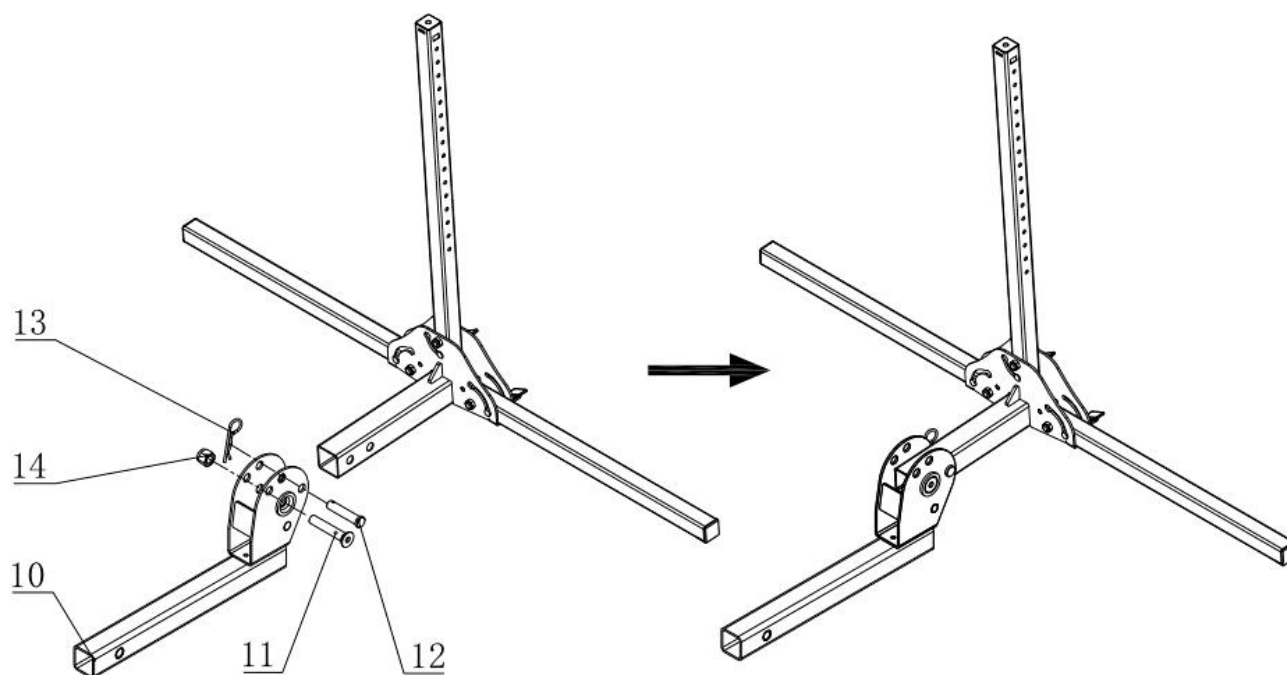

FIG 2

**STEP 3** Attach Folding Shank (part #10) to Support Base Assembly tube, using M16 Bolt, M16 Locknut, 5/8" pin and Clip (parts #11, #14, #12 & #13) for added safety. See FIG. 3

FIG 3



**STEP 4** Slide the cradles onto the horizontal arms. Release the knob of the left and right cradle (#15 ` #16). The knob should be facing up and the loop end of cradle should be facing outward and upward. Insert the cradles in sequence as shown below Fig 4. After all, 4 cradles are on the horizontal arms, tighten.

FIG 4

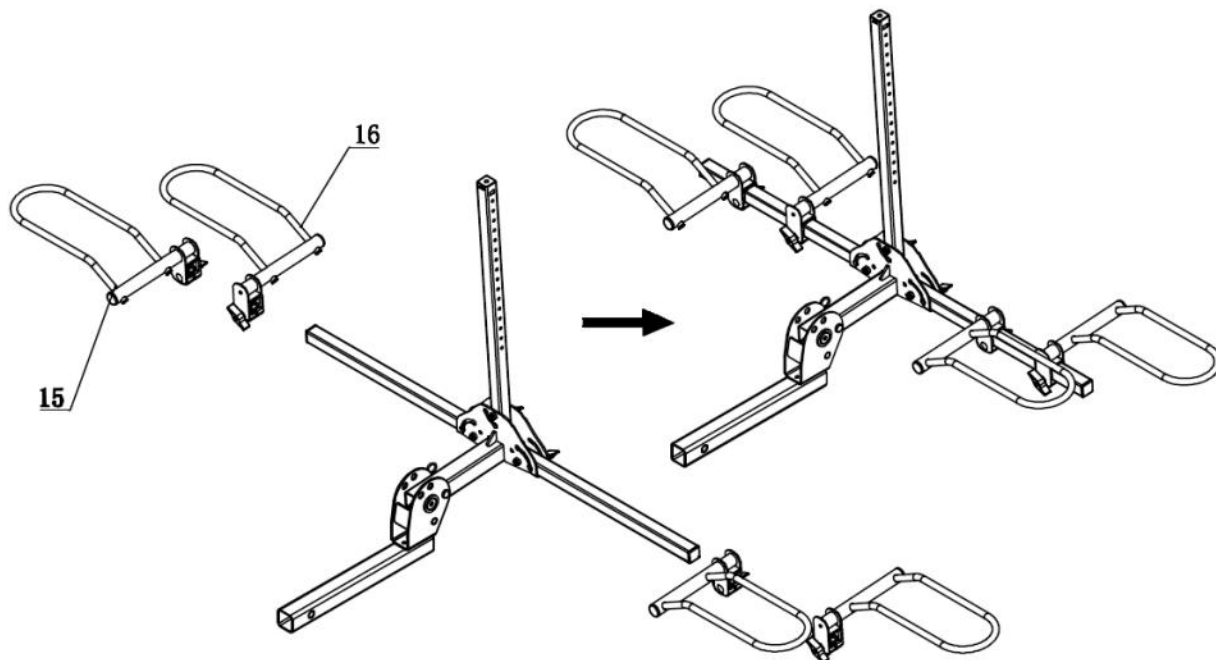

**STEP 5** Install the Long J-hook assembly (#17) and Short J-hook assembly (#18) onto the vertical arm, then tighten the eyebolt (#20). Secure the J-hooks by using snap pin (#19). Put the reflector (#21) in the hole of the square tube. See Fig 5

FIG 5

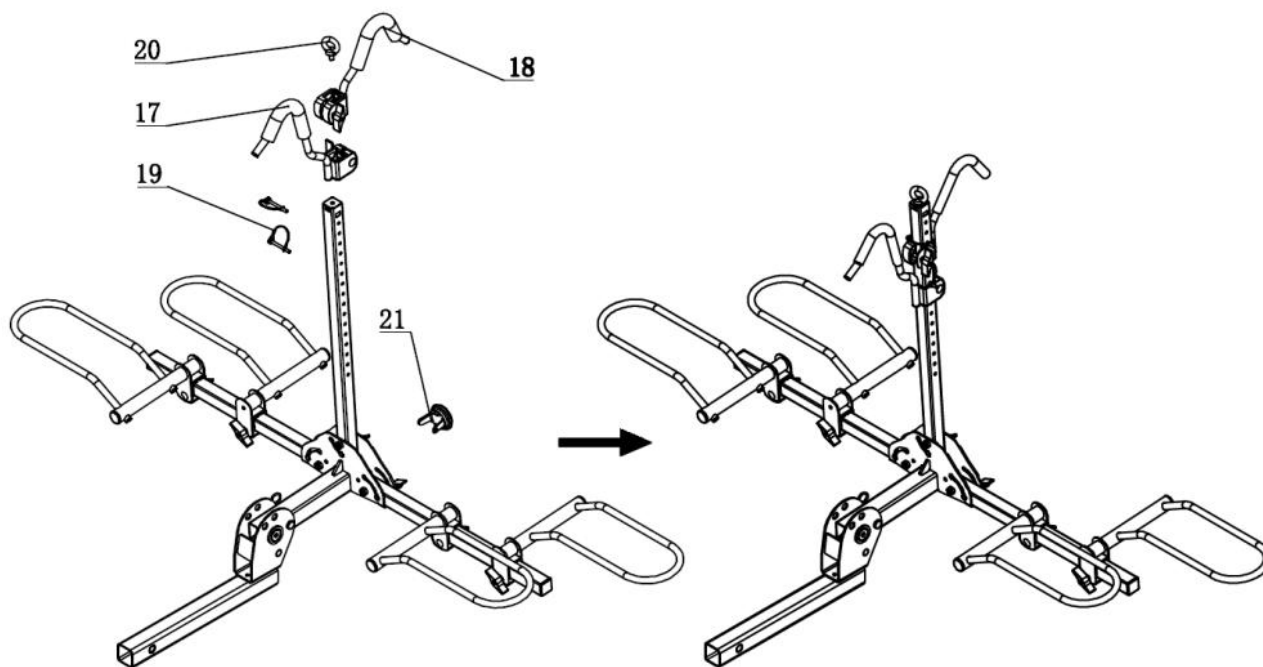

**STEP 6** Insert Folding Shank into 2" receiver, using Stabilizing Pin, 16 Spring Washer, 16 Flat Washer, and Clip (#22, #23, #24, #13) to fix.

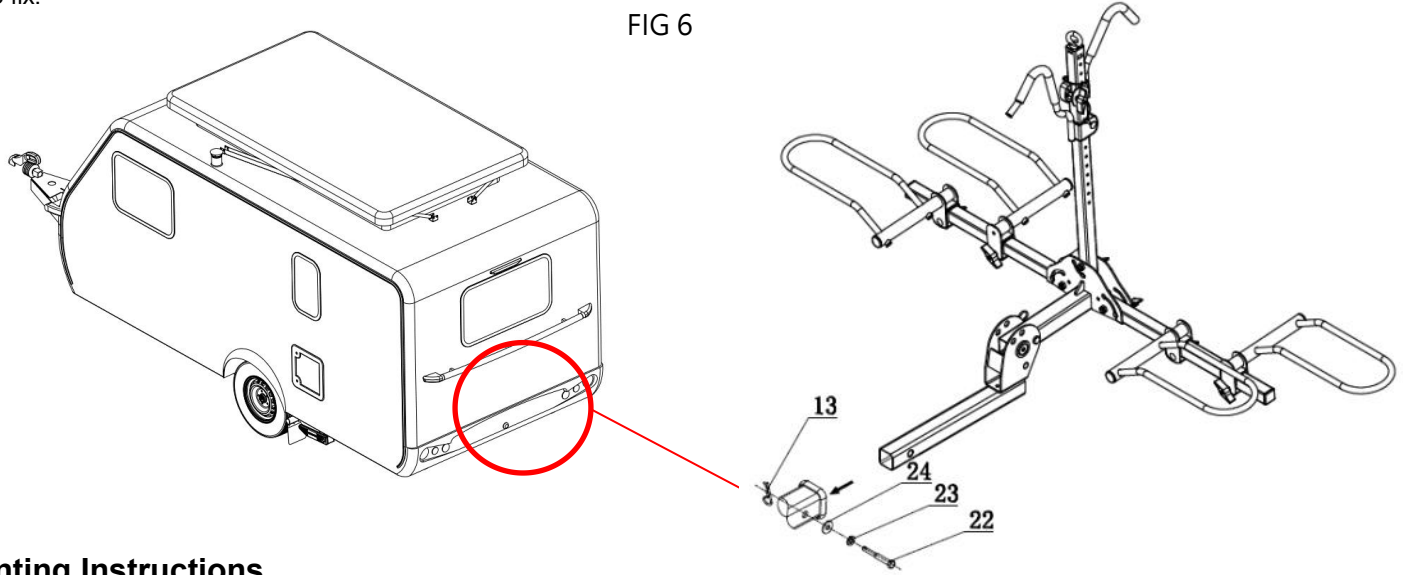

## Mounting Instructions

**Please note the cradles and J-hooks are completely adjustable and can slide on the arms.**

Using the vertical knobs on the tops of the cradle and the horizontal knobs on the J-hooks, twist until they are loose and the cradle or the J-hook can move along the tube. See Fig 7&8&9

FIG 7

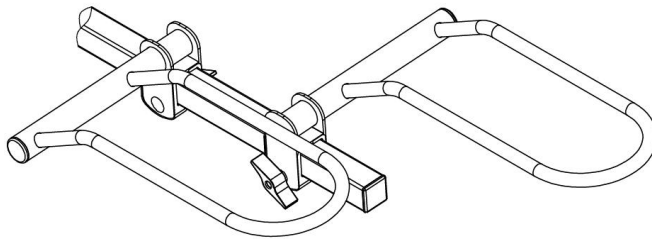

Load the bike wheels directly into the cradles and ensure they will not roll back and forth. Tighten the knobs on the cradles to lock them into position. Using the straps provided, secure each wheel to the cradles.

FIG. 8

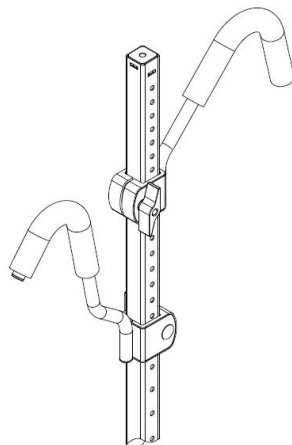

Bring down the J-hook till it fits securely over the middle part of the frame on the bike. Tighten the knobs on the J-hooks to lock them into place. Remember to use the strap on the cradles to secure the wheels. Make sure all wheels have a strap securing them.

FIG. 8

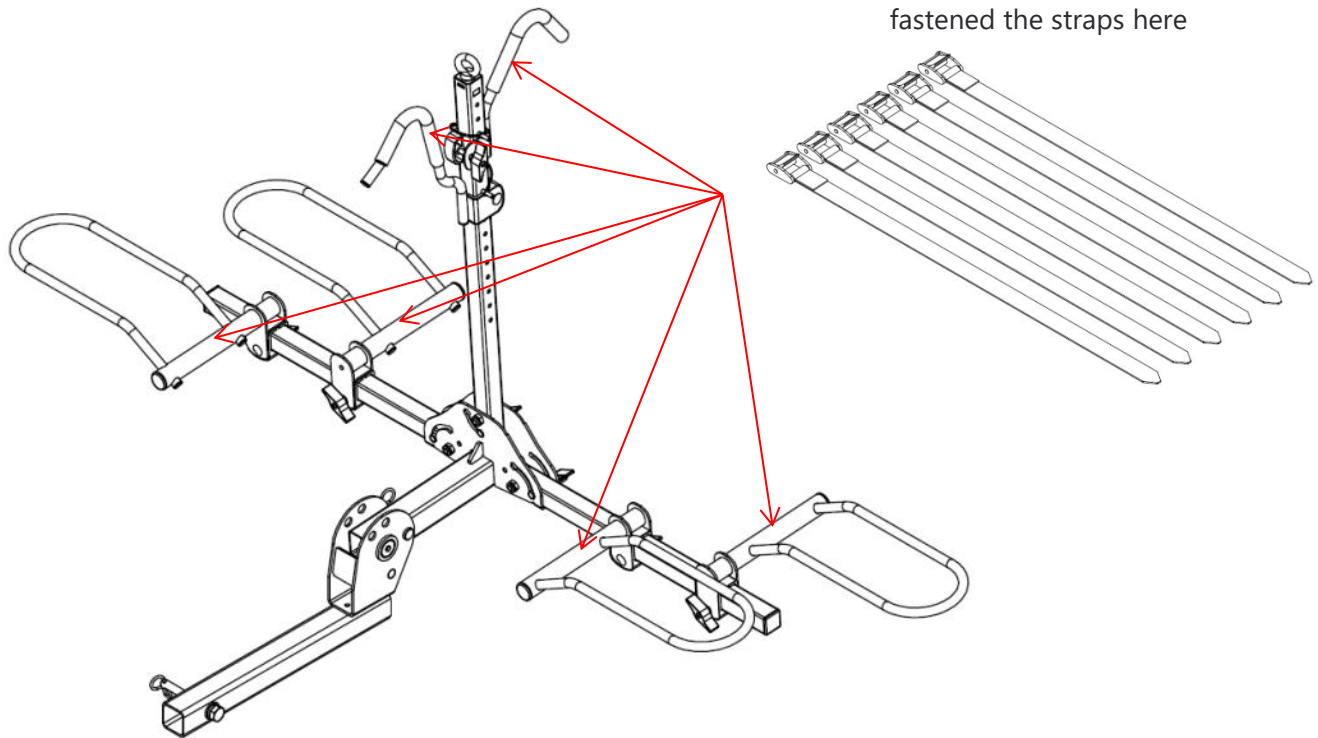

### Tilting Instructions

**DO NOT TILT TO THE RACK WHILE BIKES ARE MOUNTED**

For access to the rear of vehicle, remove 5/8" pin and allow the rack to tilt downward. Securely grasp the bike rack while the pin is out.

FIG. 9

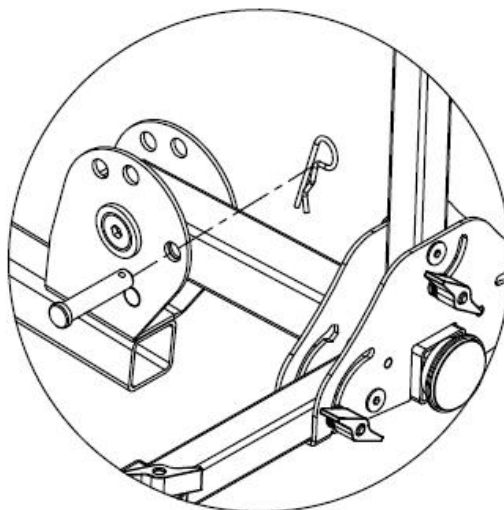

## Folding Instructions

### Method 1:

**STEP 1:** Loosen the 5/16" knob, rotate each support tube to a vertical position, and then tighten the 5/16" knob. See Fig. 10.

FIG 10

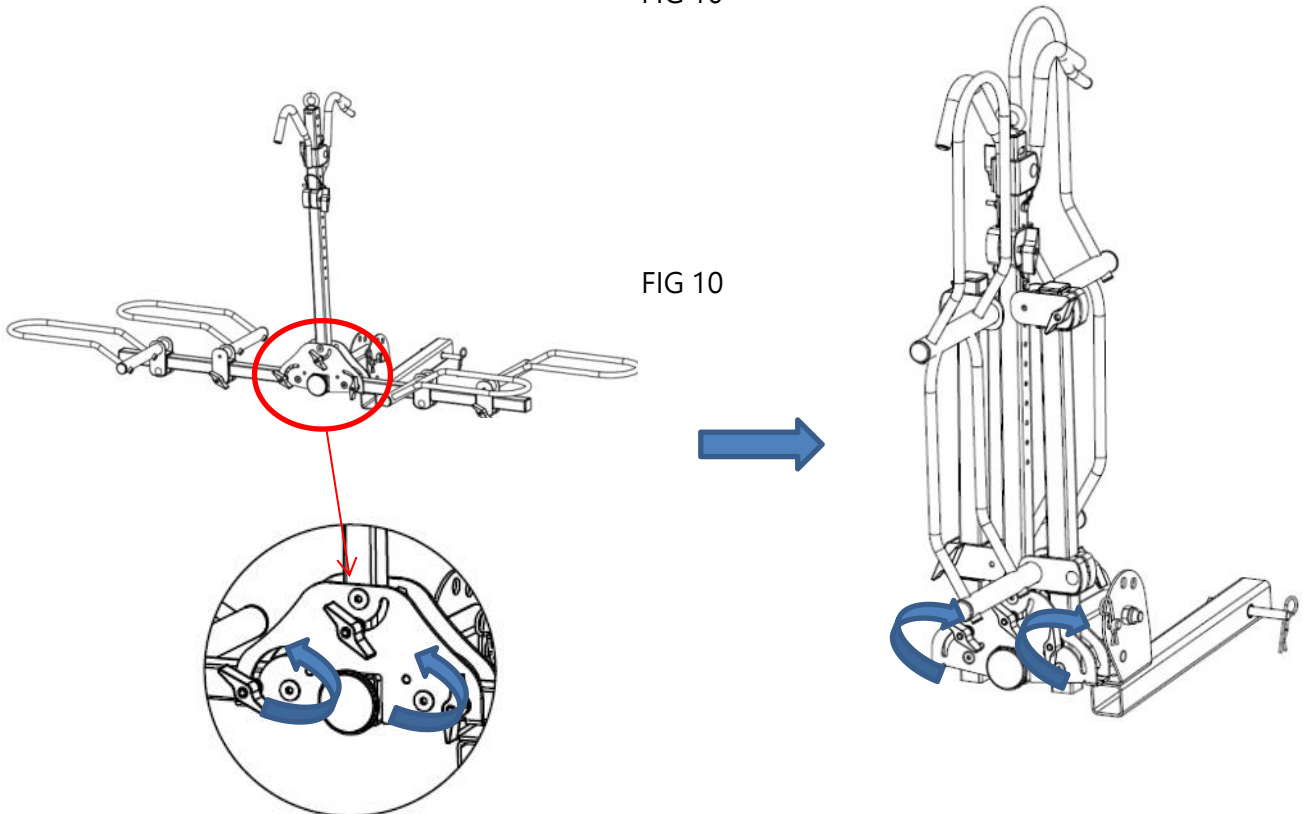
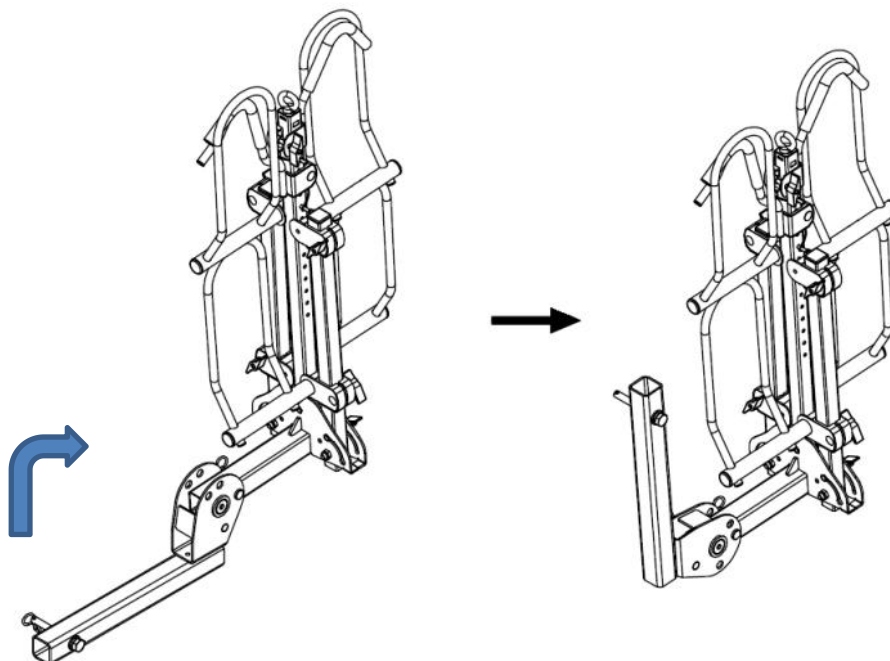

FIG 10

**STEP 2:** Pull out the 5/8" pin (12 #) and 3.8 hairpin (13 #), rotate the lifting rotating mechanism (10 #) by 90 °, and then install the 5/8" pin (12 #) and 3.8 hairpin (13 #), See Fig. 11

FIG 11



**Method 2:**

**STEP 1:** Loosen the 5/16" knob, rotate each support tube to a left position, then fasten the 5/16" knob. See Fig. 12

FIG 12

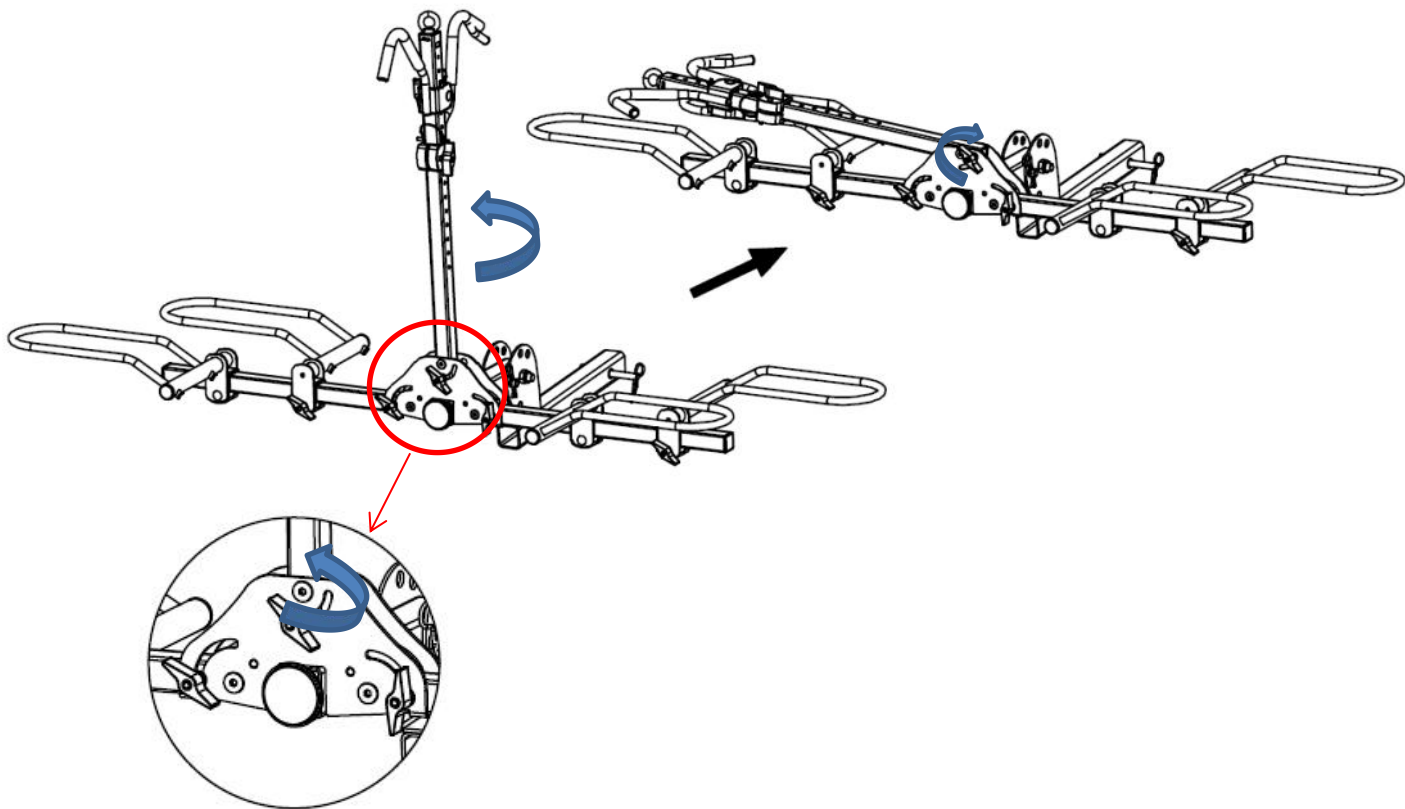

**STEP 2:** Pull out the 5/8" pin (12 #) and 3.8 hairpin (13 #), rotate the rear frame part forward by 90°, and then install the 5/8" pin (12 #) and 3.8 hairpin (13 #), See Fig. 13

FIG 13

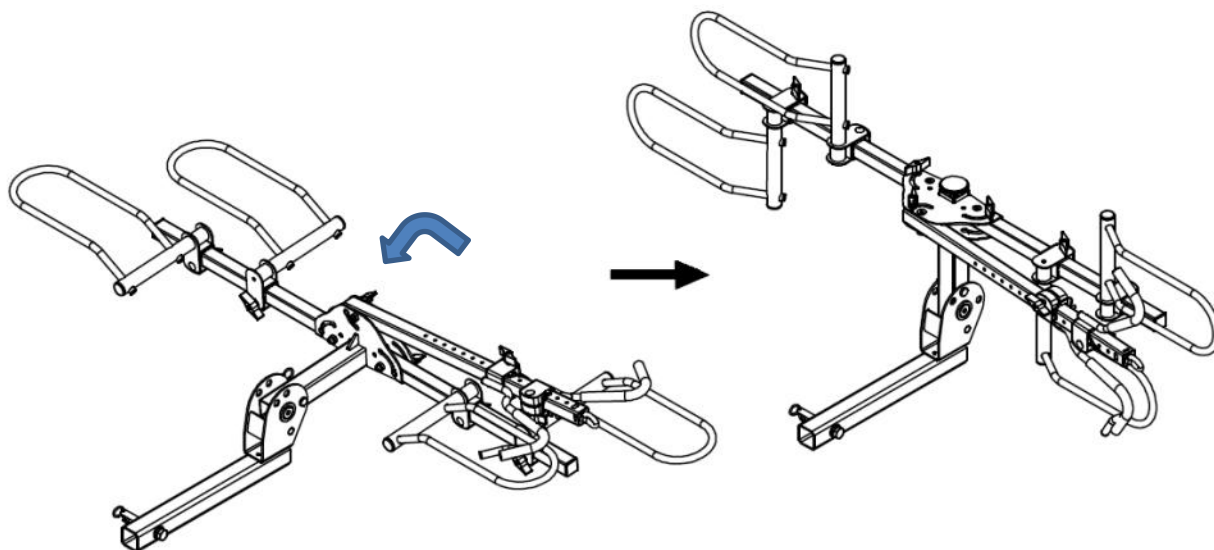



## Maintaining the Bike Rack

Frequently inspect the Bike Rack and hitch receiver for damage. If the Bike Rack or hitch receiver become damaged, stop using the product immediately. Frequently check to make sure all connections are tight and that all components are in good condition. Keep the Bike Rack clean. When the Bike Rack is not being used, it should be removed from the vehicle and stored indoors.

### Diagram

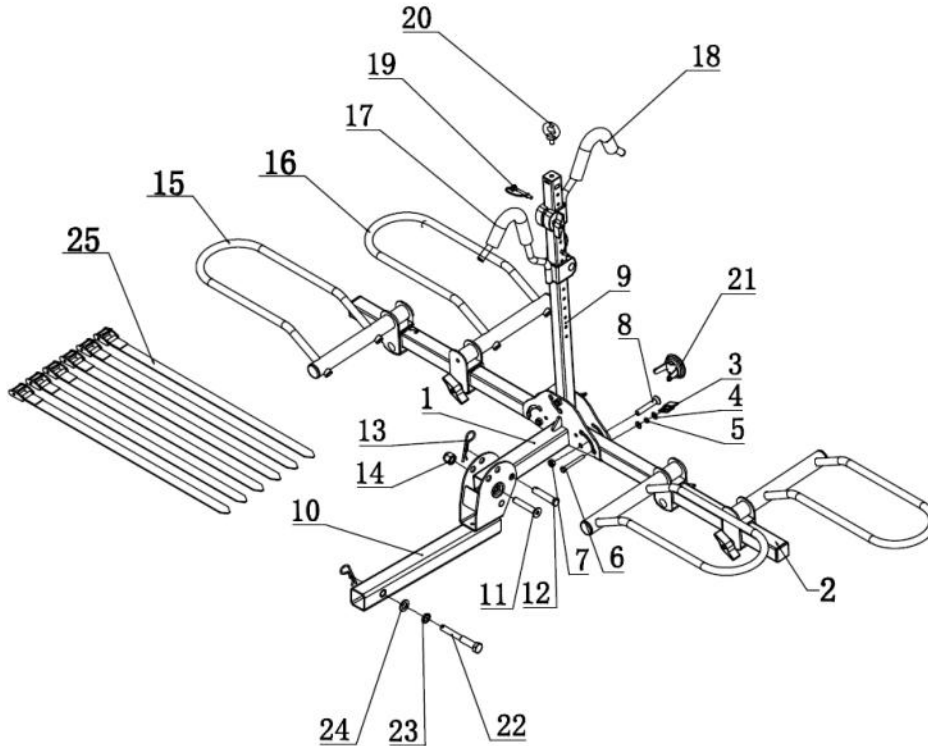

### Part List

Part#	Description	Q'ty	Part#	Description	Q'ty
1	Support Base assembly	1	14	M16 Locknut	1
2	Horizontal arm	2	15	Left cradle assembly	2
3	5/16" knob	3	16	Right cradle assembly	2
4	5/16" flat washer	6	17	Long J-Hook Assembly	1
5	5/16" spring washer	3	18	Short J-Hook Assembly	1
6	5/16" hexagon bolt	3	19	Snap pin	2
7	M10 Locknut	3	20	Eye bolt	1
8	M10 Bolt	3	21	Reflector	1
9	Vertical Tube	1	22	Stabilizing Pin	1
10	Folding Shank	1	23	16 Spring Washer	1
11	M16 Bolt	1	24	16 Flat Washer	1
12	5/8" Pin	1	25	safety strap	6
13	Clip	2			